

14375-17

A. J. DAVIES,
PATENT AGENT
AND
CONSULTING ENGINEER,
37, MOORFIELDS,
LIVERPOOL.

N° 16,564



A.D. 1908

Date of Application, 6th Aug., 1908

Complete Specification Left, 6th Feb., 1909—Accepted, 29th July, 1909

PROVISIONAL SPECIFICATION.

Improvements in and relating to the Construction of Motor Cycles.

I, ALFRED ANGAS SCOTT, Engineer, of 18 Snowden Street, Bradford, do hereby declare the nature of this invention to be as follows:—

The present invention relates to improvements in 'open frame' motor cycles, and has for its object to provide a motor cycle with a very low centre of gravity.

5 To carry out the invention,—The top horizontal tube of the ordinary 'diamond' frame is omitted, and below the diagonal tube from the steering head lug to the 'bottom-bracket' of the frame, additional duplex tubes are carried from the steering head lug to a pair of brackets hereinafter called the engine brackets, lying below the ordinary 'bottom bracket' of the frame, which
10 are connected with the rearwheel fork end lugs by a pair of tension tubes. The 'bottom bracket' is also connected with the rearwheel fork end lugs by a pair of tubes in the usual manner. The crank case of the engine is so shaped, and designed as to fit in between these engine brackets and the ordinary 'bottom bracket' of the frame, and is secured thereto by bolts; the arrangement being
15 such that the engine may be removed on withdrawal of the bolts.

The engine, which is preferably of the type described in Patent No. 3367 of 1904, has its cylinder, or twin cylinders side by side, projecting forward from the crank case in a diagonal position; more or less in line with, or parallel to the duplex tubes which connect the steering head with the engine
20 brackets.

The seat tube extends upwards from the 'bottom bracket' to a seat pillar lug to which the back forks, or tube struts are connected in the usual manner, and in the space between the bottom bracket, and the seat pillar lug is placed a tank containing the spirit, or other fuel, together with the lubricating oil.
25 The tank may be of cylindrical, or oval form, and is arranged to lie more, or less centrally over, and surrounding the seat tube.

The footboards are placed on each side of the engine, and are supported in front on coiled compression springs attached to shackles, or suitable joints at each end of a cross tube; extending below each footboard, and fixed to the duplex tubing from the steering head to the engine brackets. The rear end of each footboard is directly fastened to a cross tube extending below each footboard. This cross tube is suspended from the frame by a pair of bolts carrying coiled compression springs which are attached to a pair of plates, or bars fixed to the lower tubular stays, and to the tubular struts which connect the back
30 fork ends with the engine bracket, and 'bottom bracket' respectively. Recoil springs are also provided to check the recoil of the described springs.

The crank case casting is preferably fixed at its upper, and rear end by a single tubular bolt passing through the 'bottom bracket', and in a twin cylinder engine where two separate crank cases are employed as described in Patent
40 No. 3367 of 1904, these are combined into one casting, and in the space between the crank cases is mounted the flywheel with chain sprockets on each side. The transmission is taken by chain from these sprockets to a countershaft placed between the crank case casting, and the rearwheel, and held in moveable lugs, or clips on the lower tubular stays, and the drive is transmitted by a chain from
45 the countershaft to a chain wheel fixed to the rear driving wheel. The counter-

[Price 8d.]
PRICE 6d.

Scott's Improvements in and relating to the Construction of Motor Cycles.

shaft may be of the variable gear type having two chain wheels driven from the engine, and may be provided with a foot lever to operate the change of gear:— mounted on the same axle.

It will be seen that the described arrangement forms a dropped duplex frame of which the engine forms a central part, and serves as a strut between the 5 upper, and lower tubes.

If the engine is arranged to be cooled by water, the necessary radiators, and water tank are placed in the space above, and in front of the engine; enclosed by the upper diagonal tube, and the lower tubular stays from the engine 10 brackets to the steering head.

Dated the Fifth day of August, 1908.

ALFRED ANGAS SCOTT.

COMPLETE SPECIFICATION.

Improvements in and relating to the Construction of Motor Cycles.

I, ALFRED ANGAS SCOTT, of 18 Snowden Street, in the City of Bradford, 15 Engineer, do hereby declare the nature of this invention and in what manner the same is to be performed, to be particularly described and ascertained in and by the following statement:—

The present invention relates to improvements in open frame motor bicycles and has for its object to provide an improved frame of great strength in which 20 the tubes forming the frame are so disposed as not to be submitted to any direct bending strain applied along their length, but only to compression and tension strains. The object is accomplished by forming a frame in a similar manner to the well known diamond bicycle frame in which however the top or cross 25 bar is removed and the frame strengthened and arrangements made for carrying the engine by the provision below the usual bottom bracket of two brackets hereinafter described as the engine brackets which are connected by straight duplex tubes to the steering head and by tension tubes to the rear wheel fork 30 end lugs. At the same time a strut is provided from the bottom bracket to the engine brackets. The crank case of the engine preferably forms this strut. It will be seen from the above arrangement that the weight of the rider seated on the saddle together with the weight of the engine will put the seat pillar and the diagonal to the steering head under compression while the duplex 35 tubes from the engine brackets to the steering head and to the rear wheel will be under tension and at the same time none of these main parts of the frame will be submitted to any bending strain.

In the accompanying drawings Fig. 1 is an elevation of the motor-bicycle constructed in accordance with the present invention.

Fig. 2 a plan view of the frame.

Fig. 3 is an enlarged view showing the method of mounting the rear end of 40 the foot-boards.

In carrying out the invention the top horizontal tube of the ordinary "diamond" frame is omitted, and below the diagonal tube 2 from the steering head 3 to the bottom bracket 9 of the frame additional duplex tubes 5 are 45 carried from the steering head to a pair of brackets 6, hereinafter called the engine brackets, lying below the ordinary bottom bracket of the frame, which are also connected with the rear wheel fork-end lugs 7 by a pair of tension

Scott's Improvements in and relating to the Construction of Motor Cycles.

tubes 8. The bottom brackets 9 are also connected with the rear wheel fork-end lugs 7 by a pair of tubes 10 in the usual manner. The crank case 11 of the engine is so shaped and designed as to fit in between these engine brackets 6 and the ordinary bottom bracket 9 of the frame, and is secured thereto by bolts 12 the arrangement being such that the engine may be removed on withdrawal of the bolts.

The engine 13, which is preferably of the type described in Patent No. 3367 of 1904, has its cylinder or twin cylinders side by side projecting forward from the crank case in a diagonal position more or less in line with or parallel to the duplex tubes 5 which connect the steering head 3 with the engine brackets 6.

The seat tube 14 extends upwards from the bottom bracket 9 to a seat pillar lug 15 to which the back forks or tube struts 16 are connected in the usual manner, and in the space between the bottom bracket 9 and the seat pillar lug 15 is placed a tank 17 containing the spirit or other fuel, together with the lubricating oil. The tank may be of cylindrical or oval form and is arranged to lie more or less centrally over and surrounding the seat tube.

The footboards 33 are placed on each side of the engine and are supported in front on coiled compression springs 34 attached to shackles or suitable joints at each end of a cross tube 35 extending below each footboard and fixed to the duplex tubing from the steering head to the engine brackets. The rear end of the footboard is directly fastened to a cross tube 36 extending below each footboard. This cross tube is suspended from the frame by a pair of bolts 37 carrying coiled compression springs 38 which are attached to a pair of plates or bars 39 fixed to the lower tubular stays 8 and to the tubular struts 10 which connect the back fork ends 7 with the engine brackets 6 and bottom bracket 9 respectively. Recoil springs 38^a are also provided to check the recoil of the described springs 38. The crank case casting 11 is preferably fixed at its upper and rear end by a single tubular bolt 12 passing through the bottom bracket 9 and in a twin cylinder engine where two separate crank cases are employed as described in Patent No. 3367 of 1904, these are combined into one casting, and in the space between the crank cases is mounted the flywheel with chain sprockets on each side. The transmission is taken by chains 40 and 41 from these sprockets to a counter shaft 42 placed between the crank case casting 11 and the rear wheel 43 and held in moveable lugs or clips on the lower tubular stays 10 and the drive is transmitted by a chain 44 from the counter shaft 42 to a chain wheel 45 fixed to the rear driving wheel. The counter shaft may be of the variable gear type having two chain wheels 46 and 47 driven from the engine, and may be provided with a foot lever 48 to operate the change of gear,—mounted on the same axle. It will be seen that the described arrangement forms a dropped duplex frame of which the engine forms a central part and serves as a strut between the upper and lower tubes. If the engine is arranged to be cooled by water, the necessary radiators 49 and water tank 50 are placed in the space above, and in front of the engine, enclosed by the upper diagonal tube 2 and the lower tubular stays 5 from the engine bracket 6 to the steering head 3.

Having now particularly described and ascertained the nature of my said invention, and in what manner the same is to be performed I declare that what I claim is:—

1. Improvements in the construction of motor bicycles which consist in forming the frame in the same manner as the well-known diamond bicycle frame, but with the top or cross bar omitted and with the addition of so-called engine brackets below the usual bottom brackets which engine brackets are connected to the steering head and to the rear wheel fork end lugs by straight duplex tubes, suitable means acting as a strut being located between the bottom bracket and the engine bracket.

2. The arrangement in a motor bicycle such as described in Claim 1 of the

Scott's Improvements in and relating to the Construction of Motor Cycles.

crank case of the motor between the bottom bracket and the engine brackets in such a way that the weight of the engine is borne by the engine brackets and the crank case of the motor acts as a strut between the engine brackets and the usual bottom brackets.

3. In a motor bicycle having additional duplex tubes connecting the steering head to the engine brackets below the usual bottom bracket of the frame, mounting the foot-boards at each end on cross tubes secured to the additional duplex tubes 5 and to the back tension tubes 8 and tubes 10 respectively by means of compression and recoil springs.

4. A motor cycle constructed as described and arranged as in the accompanying drawings. 10

Dated this 5th day of February, 1909.

For the Applicant,

W. P. THOMPSON & Co.,
Chartered Patent Agents,
77 Market Street, Bradford,
6 Lord Street, Liverpool, and
322 High Holborn, London, W.C.

15

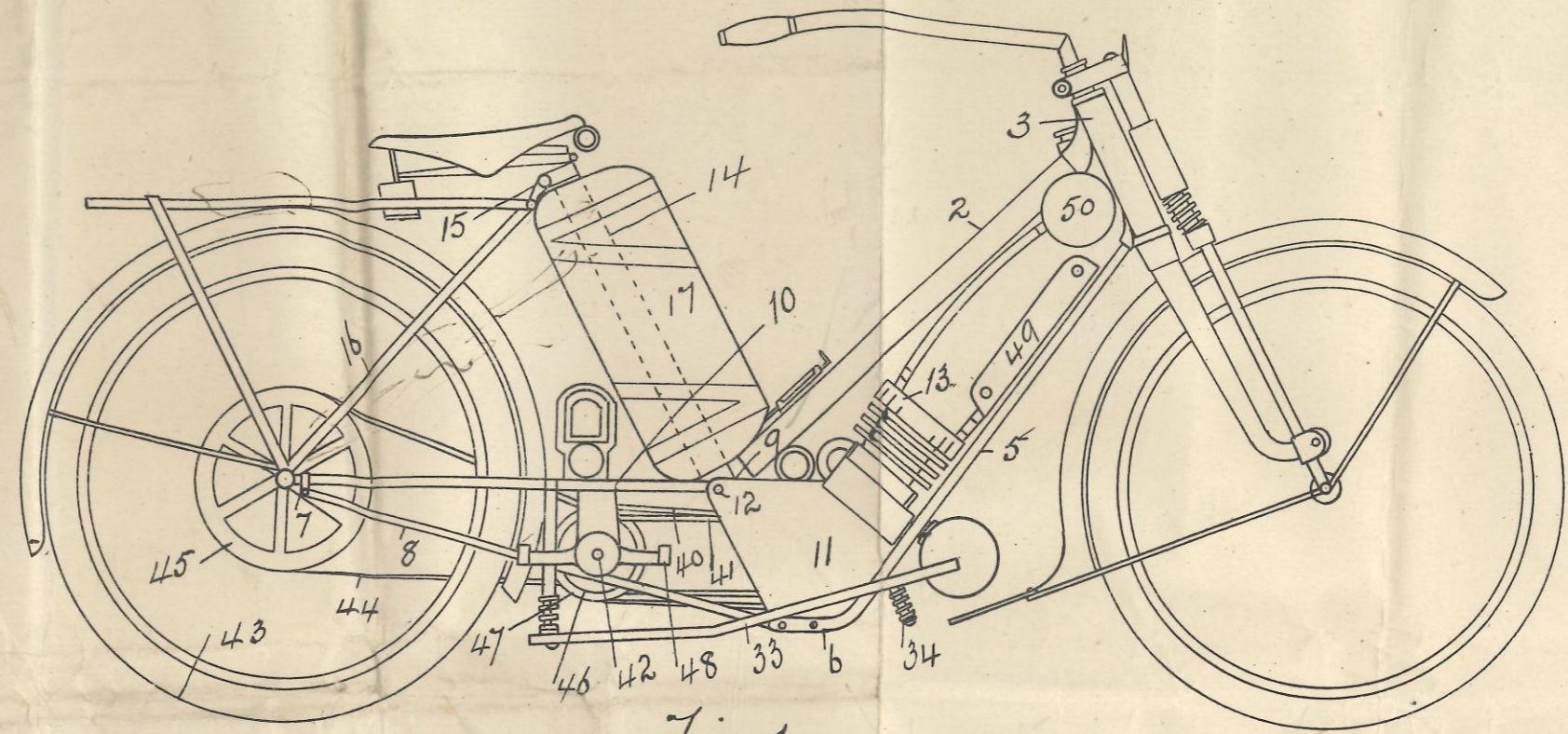

Fig. 1.

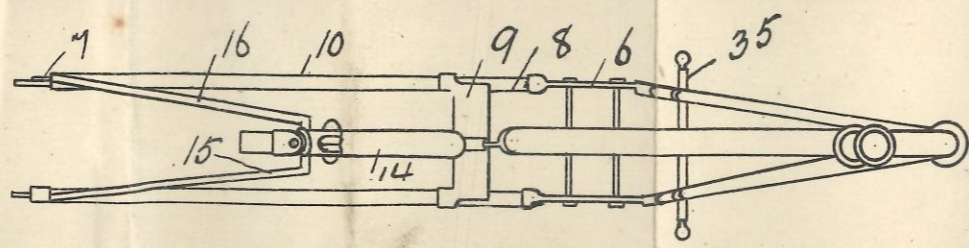

Fig. 2.

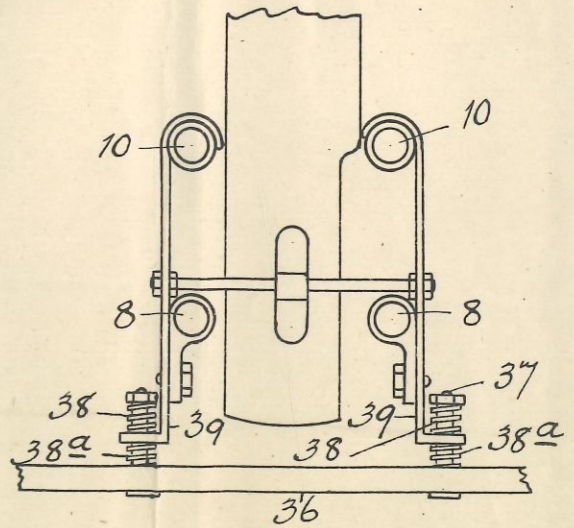

Fig. 3.

[This Drawing is a reproduction of the original in ink on paper.]