

H. G. Kitchin

The  
 BOOK  
 of  
 "The Scott"  
 DRIVING  
 INSTRUCTIONS

MADE TO LIMIT GAUGE



1930 EDITION  
 Referring to  
 Twin-Cylinder  
 Models only.

The  
 SCOTT  
 MOTOR  
 CYCLE  
 COMPY. LTD  
 SALTAIRE  
 YORKS.

THE BOOK OF THE SCOTT

INSTRUCTIONS

in the care and management of

**Scott**

MOTOR CYCLES

1930 EDITION

for Twin-cylinder Models.

Price - One Shilling and Sixpence.

SCOTT MOTOR CYCLE CO. LTD.

SALTAIRE, SHIPLEY, Yorkshire.

Telegrams "Twin, Shipley, Yorks." Telephone Shipley 337-338.

SERVICE DEPOTS:

LONDON:

78 Charlotte Street, W.1.

Telegrams

"Nonvalve, Wesdo, London."

Telephone Museum 6521.

MANCHESTER:

Liverpool Road, Deansgate.

Telegrams

"Nonvalve Manchester."

Telephone City 5992.

LEEDS

58 Woodhouse Lane.

Telegrams "Nonvalve, Leeds."

Telephone 26686.

## MAKING FRIENDS.

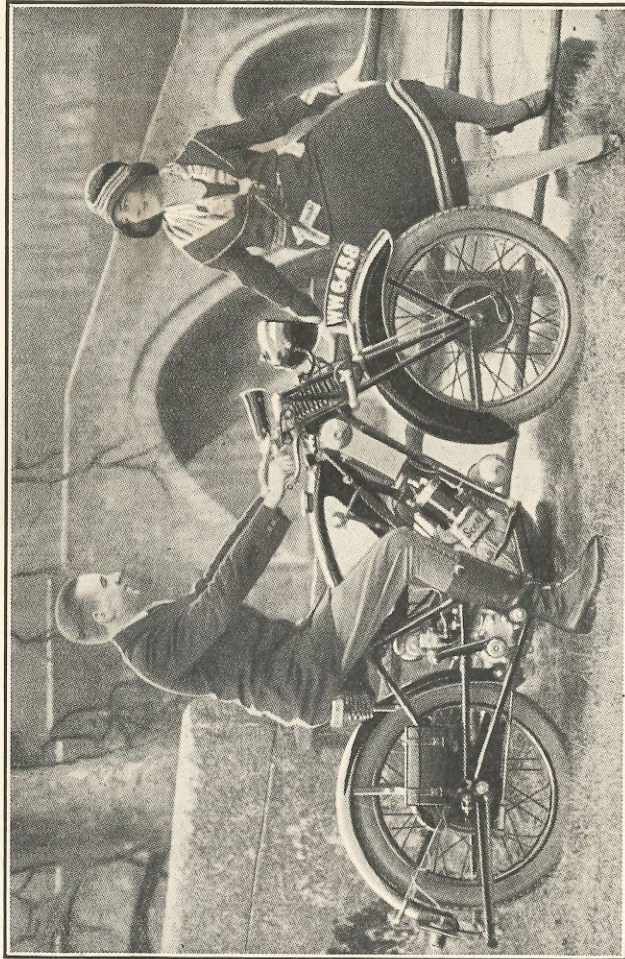

This reproduction from one of the many distinctive Scott Advertisements, could find no more appropriate place than here. Your Scott can be your very faithful friend—and the very spirit of the "Scott Clan" is Friendship.

## INTRODUCTION.

The aim of this book is to provide the complete novice, the mechanically minded, or the experienced motor cyclist, with all the particulars he is likely to require to enable him to make the most of being a Scott owner. We have, therefore, endeavoured to keep the matter in a form most easily understood by a beginner, and to enable him, by the definite and simple rules provided, to lay the foundation of intelligent and trouble-free motor cycling, and to guide him from falling into habits which can only have a detrimental effect on his pleasure.

The Scott is as simple to understand and to manage, as it is simple in principle and design, and although in many cases instructions are given in great detail (which at first sight may appear involved) they will be found quite easy in practice.

Each Scott Machine is thoroughly inspected and tested before leaving the Works, and is quite ready for service.

Before the machine is built up the Engine is given a bench test for speed and b.h.p. Then the machine is completed and is given an extensive road test for speed, pulling-power, and hill-climbing.

It is to be noted, however, that as bearings and working surfaces are machined to fine limits they remain appreciably stiff for perhaps 1,000 or even 2,000 miles' running on the road.

Careful running-in throughout this period is therefore to be desired, whilst it is necessary to provide an excess of lubricant to prevent the possibility of any working part running dry.

Such precautions are advisable with any new machine and by paying due regard to the advice given in this book the very best results will be obtained.

As instructions frequently differ according to the type of machine, care should be exercised to follow only those applicable for the particular model.

The general instructions given in this book, although primarily intended for new and recent models, apply also in many cases to earlier Scott machines.

**Separate Instructions are issued for  
the Single Cylinder 300 cc. Model.**

## IMPORTANT.

### Adjustment and Lubrication.

The following summary will be found a useful guide as to when the major items of routine maintenance work should receive attention. Of the minor items, most should be self-evident, but nevertheless, Scott riders, in their own interests, are earnestly requested to familiarise themselves with every chapter in this book.

#### Every 25 miles.

Operate 2-speed Gear Pump Plunger.

#### Every 200 miles.

Lubricate Front Fork Guides.

Lubricate Fork Crown Guide on Flying Squirrels.

#### Every 500 miles.

Lubricate Kickstarter Sleeve on 2-speed Gear.

Lubricate 3-speed Gear Operation Levers.

Lubricate Chains with Engine Oil.

#### Every 1,000 miles.

Squirt Paraffin on 2-speed Gear quick thread drums and Kickstarter Spring.

Inspect 3-Speed Gear Box for oil and replenish if necessary.

Inject oil into steering head bearing, ball race type.

Adjust steering head bearing if necessary.

#### After 1,200/2,000 miles.

Decarbonize new engine.

#### Every 2,000 miles.

Inspect piston and rings, and clean if necessary.

#### Every 3,000 miles.

Examine wheel bearings and repack with medium grease if necessary.

#### Every 3,000/5,000 miles.

Decarbonize run-in engine (with normal oiling).

#### Every 3,000 miles.

Lubricate steering head races Flying Squirrel models.

Repack 3-speed Gear Outer Bearing with medium grease.

**Note.**—If an engine is given an excess of oil habitually, it may require more frequent decarbonization; the Silencer, etc., must also be cleaned more frequently. When a machine has been driven very hard, or used in bad weather, such parts as forks, chains and wheel bearings should be lubricated at shorter intervals.

## The Book of the Scott.

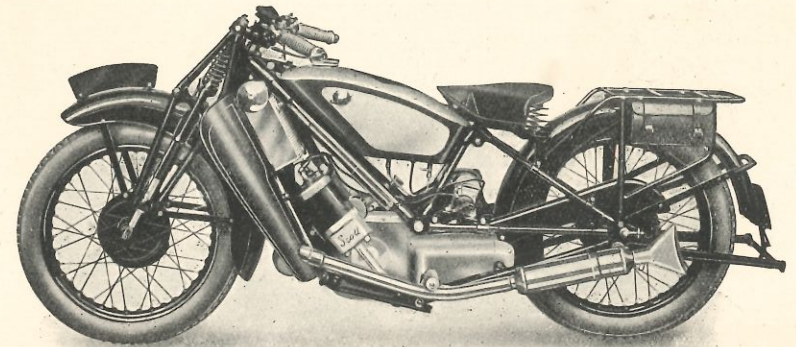

### THE NEW MACHINE.

#### I.—Before Starting a New Machine.

1. **Fill Oil Tank.** Use recommended oils of the correct grade only—preferably Castrol “XXL” for touring, and for racing, Castrol “R” together with Petroil (half a pint of “XXL” to two gallons of Petrol).

2. **Fill Radiator with Water.** If over-filled the excess will escape by overflow pipe; the level is sufficiently high if it just reaches the baffle inside filler cap orifice.

3. **Put sufficient Petrol in Tank.** With a new machine it is a good plan to mix a little oil (as used for the oil tank) with the petrol before pouring it into the tank. This supplementary “Petroil” lubrication is advised only for the first 1,000 miles or so, and for racing, and a suitable proportion of oil to petrol is approximately a quarter of a pint to two gallons.

For best results we recommend a mixture of Benzol and Petrol. 50-50.

4. See that Petrol reaches Carburetter, when tap is turned on and the “tickler” on float chamber lid is depressed.

**IMPORTANT NOTE.**—For “Running-in” see page 14.

## The Controls of the Scott Flying Squirrel.

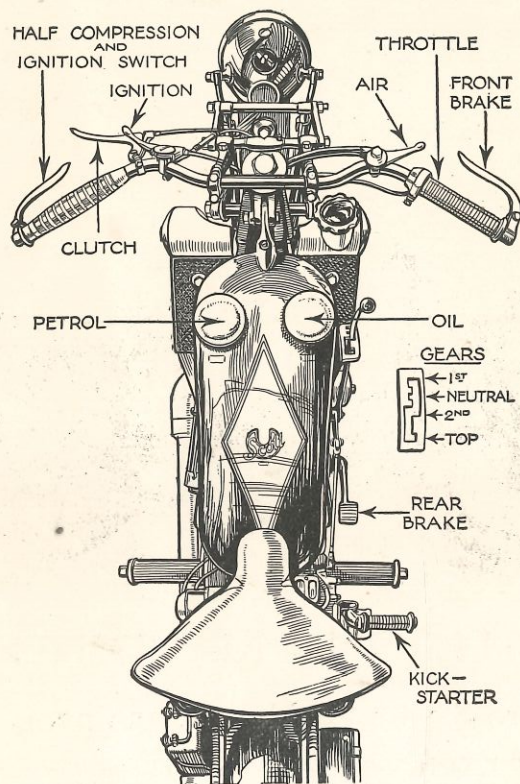

The Duplex Oil Pump, mounted on Magneto Platform, showing one of the two sight-feed regulators.

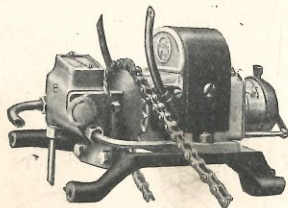

## THE NEW MACHINE.

### II.—To Start the Engine.

Having attended to the aforementioned requirements proceed as follows:—

#### 1. Set Controls.

- (a) Throttle lever (right handlebar—long lever) almost closed (it opens towards you).
- (b) Air Lever (right handlebar—short lever) closed.
- (c) Ignition Lever (left handlebar) half advanced (i.e., half-way towards you—retarded when furthest away from you).

#### 2. See that the Gear is in neutral.

- 2-Speed : When pedal is mid-way and feels free to the foot.
- 3-Speed : When lever is in notch between Low and Middle Gear.

3. **Flood Carburetter.** Depress "tickler" on float chamber lid until petrol commences to escape from top of float chamber.

4. Standing alongside machine grip half-compression lever (left handlebar) fully with left hand, and operate kickstarter gently with left foot three or four times.

Alternatively if preferred stand astride machine and operate kickstarter with right foot.

5. (a) Operate half-compression lever half way only (not to full extent as this cuts out the ignition).
- (b) Operate kickstarter smartly, when Engine should start at first or second depression.

### III.—Hints upon the Use of the Kickstarter.

Do not be tempted to "kick" it furiously; a kick does not turn the Engine over as far as does a progressive pressure, whilst it is liable to damage the mechanism sooner or later.

Place the instep or ball of the foot upon the starter pedal and press very gently until it can be felt that the ratchet has engaged. Then proceed to depress pedal smartly (but not violently), steadily increasing the pressure until the maximum is reached at about three quarters of the full stroke, after which the pressure can be eased off until the full extent of the stroke is reached.

Retain foot on pedal and allow it to return smartly but not with a jerk. The foot should not be allowed to slip off before the pedal has returned. It is inadvisable to use the kickstarter whilst the machine is on its stand.

A little practice upon these lines will make the operation of the Kickstarter unfailing and almost effortless.

#### IV.—Immediately after Starting a New Machine.

1. (a) Be careful to note that the exhaust is smoky, which indicates a sufficiency of oil. This may appear to be excessive, but is as it should be at first; surplus oil in the cylinders should quickly work off.
- (b) See that oil is dripping quickly in both sight feeds. Then, if necessary, set the regulating screws so that oil drips at approximately 20 drops per minute in each feed when Engine is running slowly. (To obtain a uniform rate of drip, the positions of the two regulating screw indicators will not necessarily coincide).
- (c) **The Exhaust should remain noticeably smoky** even after the Engine has run for a minute or two. **If it does not, stop the Engine immediately**, as it means that oil in crankcase is not at correct level.
- (d) The Exhaust should be equally smoky from each cylinder. This can be tested by detaching each plug clip-terminal in turn whilst Engine is running, taking care to hold lead by vulcanite portion to avoid shock. (The left-hand regulator supplies the left-hand cylinder).
- (e) If the exhaust continues to smoke profusely after the machine has run a few miles at moderate speed, then the oil regulators should be screwed in a notch or so at a time (at intervals of a few miles), until there is just a slight but steady blue haze.
- (f) In the most unlikely event of the pump failing to deliver oil, even upon opening up the regulators, the sight-feed window should be removed and the pump primed by filling the wells with oil; should there be an actual stoppage due to foreign matter, this can usually be cleared by running the engine with the regulator(s) entirely withdrawn (but take care not to lose the small spring-loaded plungers).
- (g) On T.T. Replica models, provided with an oil tap under the tank, be sure to see that this is turned on.

2. **To inspect oil level in Crankcases.** This is a very simple matter; remove crankcase doors as follows:

Slacken off nut holding each crankcase door strap.

Swing each strap away from crankcase door.

Operate half compression lever fully and rotate Engine by several smart depressions of starter.

Doors will then become dislodged by crankcase compression. (In the event of a door sticking it may be prised open by means of a blunt screwdriver).

The correct level is approximately half an inch below the door opening.

**Note:** When removing crankcase doors they are liable to get dirty if allowed to fall right out. This can be prevented by re-tightening strap nut to clamp strap in a position sufficiently forward to allow door to come away a quarter of an inch only. Each is then removed by hand.

Before re-fitting crankcase doors wipe the jointing washer and seating carefully, making sure that no grit adheres.

3. (2-Speed Models only). When running Engine the first time thoroughly lubricate gear by means of the plunger pump on the oil tank. This pump, it should be noted, delivers oil only to the gear, being in no way connected with the engine lubrication system. The plunger can only be pulled up when the knob is rotated to a certain position, it being provided with a bayonet catch. Where a tap is also fitted, this must be turned on before operating the plunger.

#### V.—To Stop Engine.

1. If an immediate or early restart is intended, close air lever and speed up Engine a little before stopping it with magneto cut-out (operated by full movement of half-compression lever).

2. If a restart is not to be made until three or more hours later, the Engine can be stopped by choking carburettor air intake with palm of hand keeping throttle slightly open until Engine actually stops. Then leave throttle closed. This rich mixture in the crankcase will enable Engine to be re-started almost without fail at first kick, even after standing for 24 hours or so. When leaving the machine for any length of time turn off the petrol. It is particularly important that the petrol should be turned off if the machine be left (even for a short period) tilting to the left side, as otherwise petrol is liable to flood into the crankcase and cause difficult starting; for the same reason it is a good rule invariably to leave the throttle fully closed after stopping the Engine.

#### VI.—General Hints on Starting.

1. If an Engine does not start easily and quickly it is, as a general rule, best to assume first that the Engine has sufficient rather than insufficient mixture in the crankcase, as it is easier to enrich the mixture by choking at a second attempt than to weaken it.

2. Difficulty in starting when the Engine is warm is almost invariably due to overflowing of petrol and the consequential over-rich mixture. Therefore, whilst it is of assistance to enrich the

mixture when starting from cold it is most inadvisable to do so when the Engine is hot, as considerable difficulty may be experienced. If the Engine should become accidentally choked with rich mixture, the only effective remedy is to get rid of the excess of petrol. This can be done by giving full throttle and air and clearing out the crankcases and cylinders by repeated operations of the starter, or in an aggravated case, by removing the sparking plugs, or the crankcase doors.

3. Difficulty in starting from cold is generally due to insufficient petrol and may be remedied by flooding the Carburetter liberally and covering the air intake momentarily whilst the kickstarter is operated.

## VII.—Starting Difficulties.

1. **Other Causes of Failure to Start.** (The following are unlikely but possible with a new machine).

(a) **Choked Jet.**

Symptoms: Engine fires a few times only or even not at all. Remedy: Remove jet holder at base of Carburetter, from which jet can be taken out and cleaned.

(b) **Oiled-up Plugs.**

Most probable after excessive lubrication. Symptoms: Erratic firing or failure to fire. Remedy: Remove Plugs and clean with petrol.

(c) **Contact Breaker Sticking.**

Symptoms: No spark. Remedy: Remove contact breaker cover (at side of Magneto) when rocker can usually be worked free with fingers.

If it is necessary to remove rocker, the pivot should be cleaned only, and neither scraped nor lubricated.

(d) **Attempting to start with Gear engaged or Partially Engaged.**

(e) **Attempting to start with Magneto Cut Out** by raising half-compression lever too far.

(f) **Damp or Rain-drops on Insulation** of plugs or of carbon-brush holders.

2. **Further Causes of Failure to Start.** The following are most unlikely with a new machine:—

(a) **Short circuit in cut-out wire.** This can be detected by temporarily removing contact breaker cover.

(b) **Defective Carbon-brush holder.** Vulcanite insulation should be examined for traces of sparking having occurred.

(c) **Incorrect timing of Magneto.** See Instructions on Timing.

(d) **Firing on one Cylinder.** This suggests an air leak on the other cylinder provided no other fault can be traced.

(e) **Compression leakage from crankcases.** Usually noticeable by leakage of Oil.

## I.—Gear Operation: 2-Speed Models.

Having started the Engine:

1. Set throttle so that Engine runs slowly.

2. Place heel of foot on rear arm of gear pedal and press gradually until gear begins to engage. Open throttle slightly as Engine slows down, and continue to open it gradually as the load is taken up.

**N.B.**—Unless this is done the Engine may stop or the gear engage too harshly. If the gear is too fierce, engage it by a more gentle pressure on the pedal or speed up the Engine a little more whilst the load is being taken up (but the latter should not be overdone).

3. When machine has got well under way give rear of gear pedal a smart tap, thus locking it into gear.

4. When 20 m.p.h. (approximately) has been attained, engage high gear by pressing heel of foot on front arm of pedal. At the same time throttle should be half closed momentarily or half-compression lever operated.

5. Gear should not be allowed to slip to any appreciable extent when changing into "high." Movement of Pedal should be smart but not violent. A further tap of the heel will then lock gear into position.

6. To change from high to low gear press rear arm of pedal firmly with heel, at the same time opening throttle very slightly if it is not already open appreciably. If the change down is made too slowly the Engine will speed up too much. If it is made too suddenly the Engine will not have time to attain the requisite speed for the lower gear ratio. A change down should never be made at a higher road speed than the machine can do comfortably on low gear.

**N.B.**—The above instructions apply primarily to changing down when climbing hills, and not necessarily to changing down at low speed such as when negotiating traffic, etc. In such cases the Engine need not be accelerated, whilst the gear may be allowed to dwell in neutral, if desired, during the change.

When manipulating the gear at low speeds, care should be taken not to re-engage high gear before the machine has acquired sufficient road speed.

There is no harm in using low gear as an additional brake when descending steep hills, but it must be fully engaged and the engagement not too sudden. The throttle should be kept shut, whilst the Magneto cut-out should not be operated as this tends to oil up sparking plugs.

## DRIVING INSTRUCTIONS.

7. To put gear into neutral, press the whole of the pedal with the flat of the foot, i.e., depressing rear arm if in "high" or front arm if in "low." The gear is in neutral when the pedal is mid-way between the two gears and when it feels free to the foot.

It is advisable to practice the manipulation of the gear before going on the road, particularly the method of instantly finding neutral position.

## II.—Gear Operation : 3-Speed Models.

Having started the Engine :

1. Set throttle so that Engine runs slowly.
2. Disengage clutch fully. This is done by gripping the top lever on left handlebar.
3. After a momentary pause move gear lever into low gear notch.

**Note.**—Occasionally a silent engagement may be difficult owing to congealed oil on the clutch plates, but these can be freed by stopping the engine and operating the kick-starter with clutch disengaged.

4. Engage clutch gently (by releasing handlebar lever) accelerating Engine slightly as it takes up the load.

5. When 10 m.p.h. (approximately) has been attained, change into middle gear. This is done by closing the throttle lever, disengaging the clutch and moving gear lever into middle notch. The exact position can be felt immediately, but care should be taken not to let it remain accidentally in the neutral position between "low" and "middle." The throttle can then be opened again immediately, the "change" occupying less than a second.

6. When 20 m.p.h. is attained, change into high gear by precisely the same method, moving gear lever into the appropriate notch.

7. To change down from "high" to "middle" or "middle" to "low," first open throttle slightly, then disengage clutch (but not necessarily fully) simultaneously moving gear lever into the desired notch. Then release clutch lever smartly.

**N.B.**—Do not change down at a higher road speed than can be done comfortably in the lower ratio.

No attempt should be made to change direct from "high" to "low" or vice versa.

The use of the half-compression or magneto cut-out lever is not advised when changing up on three-speed models, except with close ratio-boxes, and even in this case a certain amount of skill is required to avoid risks of sudden jars and damage.

## DRIVING INSTRUCTIONS.

8. To put gear in neutral, from either low or middle gear, disengage clutch and move lever to neutral notch. To do this from high gear a normal change must first be made into middle gear, pausing momentarily before going through to neutral.

The above instructions apply when the machine is in motion. If it is stationary but the Engine is running, the clutch must be kept fully disengaged until the lever is in the neutral notch, when it may, of course, be released.

When the Engine is not running no attempt should be made to force the gear lever. It is advisable to move the machine very slightly backwards or forwards to obtain easy engagement, or alternatively to turn the Engine slowly over with the kickstarter until the gear lever moves freely into neutral position.

**N.B.**—On no account must a gear be engaged when the machine is in motion with the Engine stopped, as could happen if descending a hill in neutral. Under such circumstances the general practice with Gear Boxes should be observed, i.e., the machine must be brought to rest first and kickstarted, or the gear can be engaged when standing and the Engine started with the machine's momentum upon releasing clutch.

## III.—To Stop the Machine.

When driving, the actual speed is, of course, controlled by the throttle lever, all other controls being utilised only to obtain the best running conditions for the particular circumstances. Therefore, to slow the machine down the throttle should be closed, and if this does not pull the machine up quickly enough the brakes must naturally be applied. It is better practice to apply the rear brake before the front brake, and unwise to use the front brake to any great extent unless the rear brake is also being used at the same time.

Before bringing the machine to rest the gear should be slipped into neutral, although this is not essential if the machine is already in low gear.

If an immediate re-start is to be made, the Engine need not be stopped but should be throttled down to prevent needless racing.

**In an emergency** there are other means of stopping the machine :—

The most obvious is to operate the half-compression lever fully, thus cutting out the Magneto.

The maximum braking action of the Engine can be employed by engaging low gear, but it must not be engaged suddenly at too high a speed.

#### IV.—Correct Control of the Engine.

1. **The air lever** provides a means of adjusting the richness of mixture to a nicety, and should not be disregarded. Generally speaking (with normal jet setting) it will be necessary to have this partially closed when running at very low Engine speeds or when the pulling load is great. At medium speeds the air can be fully opened, but at full throttle it is sometimes necessary to close the air slightly.

The symptoms of too rich a mixture are "four-stroking" (i.e., cylinders firing only every other revolution), or general erratic running. The symptoms of too weak a mixture are "knocking" (even when ignition is retarded) or fading away of power.

2. **The ignition lever** determines the exact moment at which the spark takes place in the cylinder, the timing of which should be early (i.e., advanced) at high speeds and late (i.e., retarded) at low speeds when, of course, running under load. It should also be retarded slightly when the Engine is pulling hard, or if any "knocking" can be heard.

The appropriate setting of both air lever and ignition lever can be found best by experiment, and the lines to work upon are to give as much air and as much advance of the ignition as will give maximum power and easy running.

3. **To slow down.** When it is desired to reduce the speed of the machine, the best practice is to close the throttle lever fully, as partial closing causes increased suction on the jets and consequent over-rich mixture (apart from extravagance of petrol, this may result in erratic firing whilst slowing down). When the speed is sufficiently reduced the throttle should be opened again, just enough to maintain the desired speed, when, being under load the Engine will proceed to fire quite evenly.

If very low speeds are desired, use low (or middle) gear—this is one of the purposes of a lower ratio, whilst advantage may also be taken of the half-compression lever, which can be used extensively.

4. **To Run-in a New Engine.** In addition to observance of lubrication instructions affecting a new machine, the Engine must be handled very carefully throughout its running-in period. It must be driven as much as possible at its most "comfortable" speed, i.e., when it is firing evenly and smoothly without apparent effort. Suitable speeds are 20 to 35 m.p.h. in high gear, the lower gear (or gears) being used when it is desired to travel slowly.

No harm will result from running faster—provided the Engine is not "forced," or expected to accelerate too quickly.

If it is desired to sample the machine's speed capabilities before the Engine is run-in, a speed in excess of 40 m.p.h. must not be maintained for any length of time, and the oil pump should be opened up previously to deliver a constant stream of oil.

Whilst an Engine is new it naturally demands a somewhat richer mixture than normal and on this account the petrol consumption may appear to be a trifle extravagant at first.

The treatment of any good machine in the early stages of its life is most important as it can well make or mar its subsequent efficiency.

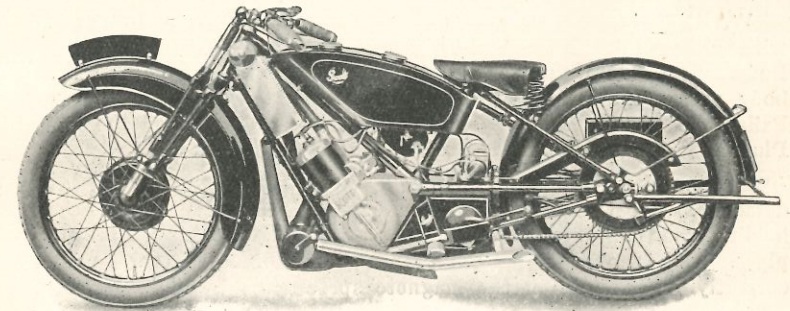

THE SPORTS SQUIRREL.

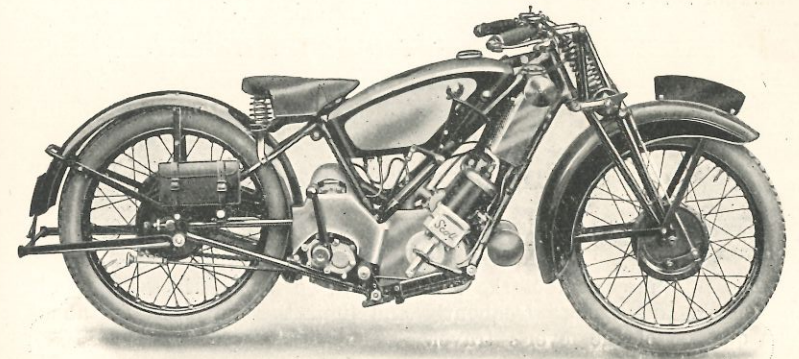

THE FLYING SQUIRREL (TOURER).

# LUBRICATION.

## I.—Engine Lubrication.

Always use a high quality oil and be careful to select the correct grade.

We recommend WAKEFIELD CASTROL "XXL."

If unobtainable any of the following may be used :

Prices' Motorine. Speedwell "Sans Egal."  
Vacuum "T.T." (improved). Castrol "XL."

Substitutes for the above (unless of known and irreproachable quality) and all unbranded oils should be avoided.

### Pilgrim Duplex Pump.

**WARNING.**—The Pump Driving Worm must never be revolved with either the End Plate or End Cam removed from the Pump Body. The Pump Plunger must never be removed from the Pump body unless the Driving Worm and Bush have been first removed. Failure to observe these points will immediately render the Pump Plunger and Driving Worm liable to serious damage.

The pump when mounted alongside the magneto sprocket is easily detachable from the magneto platform by undoing the two bolts holding the pump bracket to the platform, and taking off the oil pipes. On replacing, see that the pump spindle driver registers correctly in the hole in the magneto sprocket.

The crankcase-mounted pump of the Power-plus Engine is a unit with the crankcase door which can be removed bodily after detaching the two clamping straps. In this case, the pump spindle is made in one piece with the driving disc. When replacing pump unit, be very careful to see that slot in disc engages positively with boss on crankpin screw.

### Auxiliary Cylinder-Wall Oiling for Racing.

This hand-operated oiling system, fitted only to the T.T. Replica, enables additional oil to be pumped direct to the pistons and cylinder walls as required.

It is intended to be used only for racing, as the mechanical pump is capable of supplying sufficient oil for all ordinary purposes.

The operating lever is at the left-hand end of the handlebar, and controls a plunger pump incorporated in the oil tank.

The full movement of the lever should be rarely necessary. It is preferable to oil more frequently and limit the movement to about one quarter of the lever's travel.

On no account should the lever be operated with the engine stopped, as the oil thus accumulated would render starting difficult and possibly cause the plugs to oil-up.

# LUBRICATION.

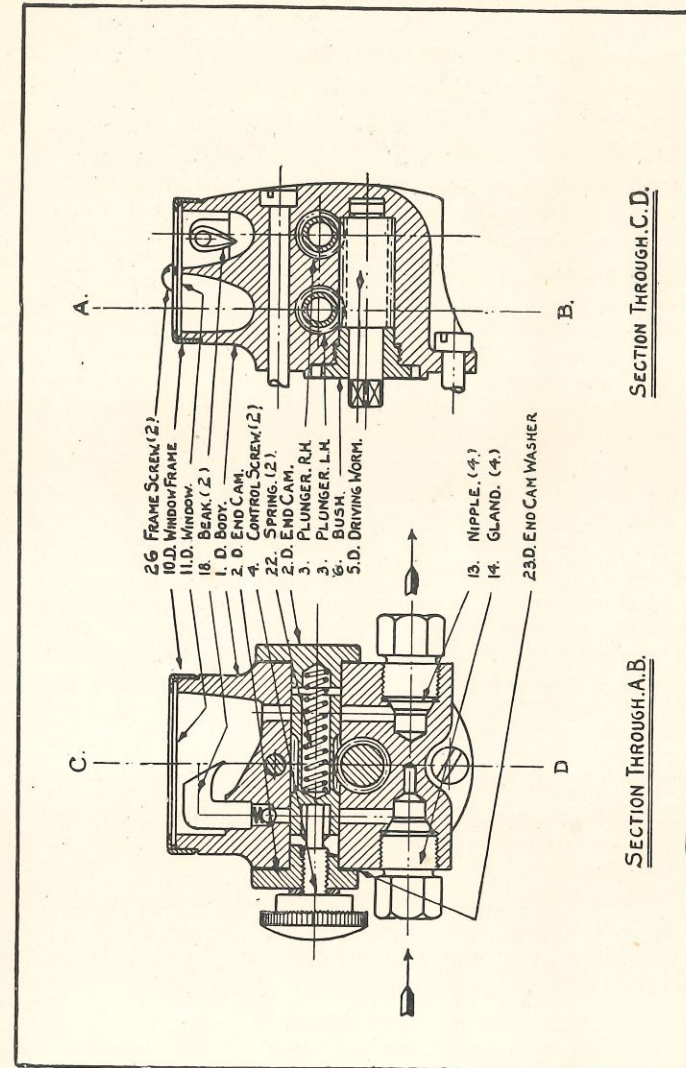

Sectional Drawings of the Pilgrim Duplex Mechanical Oil Pump.

## II.—The Scott Lubrication System.

All present Twin-Cylinder Models are fitted with mechanical twin sight-feed pumps. The usual position is on the magneto platform, but with Power-plus Engines, on the right-hand side of the crankcase. In the first case the drive is taken from the magneto sprocket (through a driving arm), and in the latter through a driving disc (engaging with a boss on the crankpin) carried by a substantial bearing in the special conical crankcase door.

The system is quite automatic, except for the periodical adjustment of the regulating screws, the feed commencing and ceasing with the starting and stopping of the engine. Oil is delivered, under pressure, to each crankcase individually, through timed ports in the crankshaft packing glands, embodied in the main bearings. Every internal part of the engine is efficiently lubricated by oil flung from the cranks and by the oil-mist alternately carried in suspension and dispersed by crankcase suction and compression, whilst oil-wells maintain a constant reserve supply. On the Power-plus engines, oil passes from the main-bearings by centrifugal force to a collecting channel undercut on the inner face of the crank disc, whence it is led centrifugally via the drilled crank pin direct to the big-end rollers.

## III.—Oil Pump Regulation.

With a new machine the Engine must be liberally supplied with oil until it is thoroughly run-in (throughout its first 1,500 miles at least). The sight feeds should, therefore, be regulated to deliver about 20 drops per minute at low speeds, whilst the use of "petrol" is an additional safeguard. During this period the Engine should be allowed to smoke freely if occasional high speeds are indulged in, whilst at all speeds it should be kept smoking very slightly.

The Normal Oil Setting, when an engine has settled down, is best determined by experiment, but is usually such that allows drips at the rate of about 10 to 15 per minute in each feed. The rate of feed will automatically increase at higher Engine speeds and decrease at lower speeds, but it is advisable to check this and re-adjust the regulating screws if necessary to suit particular circumstances.

The exhaust furnishes the most reliable guide to correct lubrication. Excessive blue smoke denotes too much oil. Complete absence of smoke denotes insufficient oil.

When an Engine is run-in, the supply of oil is correct if it does not smoke noticeably at medium speeds, but smokes very slightly when accelerating suddenly in low gear. Another simple test is to operate the half-compression lever, releasing it smartly, when at a medium speed a faint puff of smoke should be noticeable.

**N.B.—**The crankcases contain only sufficient reserve oil for five miles at low speed. Remember this if you run out of oil.

## IV.—General Lubrication.

**Lubrication of Two-Speed Gear.** Oil is fed to the gear direct from the tank and the plunger pump should be operated once every 25 miles. When operating the pump the tap should be turned on (the provision of this tap is merely to safeguard against possible leakage past the pump ball-valves when out of use). The plunger can be locked in the "off" position by the bayonet catch provided.

**The Kickstarter** (2-Speed Models) should be kept clean and well lubricated. Flush with Paraffin occasionally and oil the sliding sleeve every fortnight or 500 miles.

**Lubrication of Three-Speed Gear Box.** This is designed for lubrication with the same oil as used for the engine, and thicker oil is not advised. The gearbox should be inspected about every 1,000 miles and oil replenished if necessary.

The oil level plug (it is a hexagon headed plug situated at the front end of the lid on the box centre) should be removed when filling, the correct level being when the oil has reached this opening.

The outside bearing which supports the driving sprocket should be examined and repacked with grease if necessary about every 5,000 miles. To do this, remove bearing end plate which screws out of the bearing bracket. The clutch withdrawal race should be oiled occasionally.

**Lubrication of Chains.** All the Chains should be lubricated about every 500 miles with Engine Oil, or if preferred, treated with Graphite Grease. They should never be allowed to run dry. Oil may be applied to Engine Chains by means of a Brush or oil-squirt when the Engine is running. The Driving Chain should also be removed periodically, brushed with Paraffin and soaked in warm grease. (Chain oilers, as fitted to T.T. Replica Model can be supplied for other Models at extra cost. These are not intended to be used continuously, but only to be turned on as occasion demands).

**Lubrication of Spring Forks on Super Squirrels.** The upper sliding tube of the Spring Case is packed with Grease which will last almost indefinitely, but additional lubricant can be inserted by prising open the Spring Cap on the steering head. The slides at the fork ends are lubricated automatically by oil retained inside the fork members, which should be replenished every 200 miles through the holes provided in the fork crown.

**Scott Girder Forks.** One oil cap will be found on the top fork lug for the sliding fork crown, and two on the sliding fork crown for the fork guides. Injections of oil should be given every 200 miles. Grease must not be used.

## LUBRICATION.

**Webb Pattern Forks (Flying Squirrel).** These should be lubricated every 2/300 miles by Grease Gun.

**Lubrication of Wheel Bearings.** The hubs of all Models are lubricated by medium grease which should last without attention for approximately 3,000 miles. There is no harm, of course, in replenishing the supply more frequently, and this is advisable when the machine is used in very bad weather.

On Flying Squirrels the wheel hubs are provided with nipples for use with the Grease Gun supplied.

**Steering Head Bearings** on Flying Squirrels should be lubricated every 3,000 miles, by means of Grease Gun.

**General.**—Such parts as brake and gear operating mechanism, and controls in general, require periodical cleaning and oiling. Bowden wires, though so frequently left to look after themselves, will last infinitely longer and function more satisfactorily if occasionally lubricated. A very thorough, yet quite simple, method of doing this is to disconnect the upper end and to slide onto it a short length of rubber tube (tying it with string if a slack fit). A mixture of thick oil with a little petrol, poured into the tube will quickly penetrate to the full length of the cable.

In conclusion, although Scott machines can withstand a surprising amount of neglect, they deserve reasonable attention, and what is more, they will repay you for it handsomely.

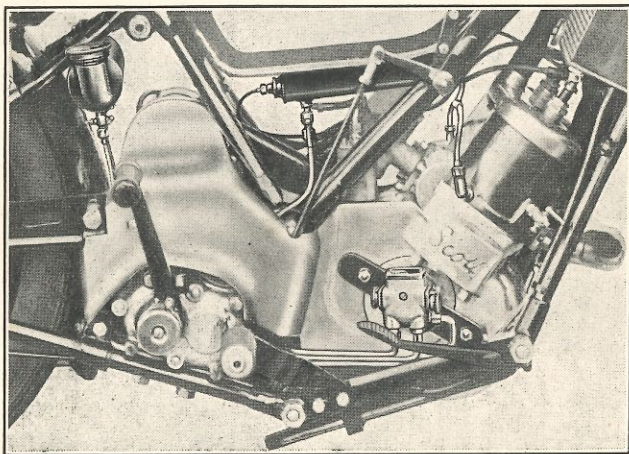

Showing Lubrication Details of Power-plus T.T. Replica.

## THE SCOTT ENGINE.

The Scott Twin is unique amongst high-efficiency engines in the extreme simplicity of its design and working principles. There is a complete absence of small working parts such as the valves of a four-stroke engine, and the necessary operating gear; hence there is nothing to demand frequent adjustment or attention, and provided the engine is treated with a normal degree of care, it can maintain its "tune" over abnormally long periods.

### I.—Its Action.

The action of the "SCOTT" 2-stroke Engine should be understood if an interest is to be taken in the machine, as this knowledge is of assistance both to correct driving and treatment when carrying out an overhaul.

The whole Engine is so simple both in principle and practice that it can be readily understood after a few moments' thought.

"The 2-stroke Cycle" as employed in the Scott is briefly as follows:—

1. Assuming that the Engine is being rotated by means of the starter the piston ascends the cylinder and causes a powerful suction in the crankcase (which is hermetically sealed by automatic packing glands). See diagram (a).
2. When the piston almost reaches the top of its stroke a series of inlet ports in the Cylinder lower wall are uncovered by the bottom edge of the piston. Atmospheric pressure then forces a full charge of mixture from the carburetter to the crankcase. See diagrams (b) and (c).
3. The piston immediately closes these ports upon commencing its descent and the charge in the crankcase is then compressed. See diagram (d).
4. When practically the bottom of the stroke is reached (and the crankcase compression is at its maximum) the top of the piston uncovers a transfer port in the cylinder wall (somewhat above the inlet ports). This transfer port communicates with the crankcase from which the compressed charge is instantly transferred to the combustion chamber (i.e., the cylinder proper). See diagrams (e) and (f).
5. The transfer port is closed again by the further ascent of the piston and the charge compressed ready for the explosion to take place. Refer back to diagrams (a) and (b).
6. The spark is timed to occur at approximately the top of the stroke and the piston again descends by the force of the explosion. See diagrams (c) and (d).

## THE SCOTT ENGINE.

7. Before the piston has fully descended its top edge uncovers a large exhaust port in the cylinder wall opposite to the transfer port, and the burnt up gases escape by reason of their own force, reducing the pressure of the combustion chamber to that of the atmosphere (or even less on account of the "extractor" effect of the exhaust pipe). See diagram (e).

8. Immediately this condition has been reached the transfer port is again uncovered (it being almost at the bottom of the stroke) and as explained in paragraph 4 a fresh charge of explosive mixture fills the combustion chamber. By reason of a simple deflector formed on the head of the piston this charge is directed to the top of the cylinder first so that the possibility of any new gas being lost through the exhaust port, whilst that remains uncovered, is reduced to a minimum. See diagram (f).

The cycle of operation then proceeds as explained in paragraph 5 and onwards. It will, of course, be appreciated that when the Engine is running the induction (explained in paragraphs 1 and 2) takes place simultaneously with the compression of a previous charge (explained in paragraph 5). Similarly the compression of a crankcase charge (paragraph 3) takes place simultaneously with the explosion of a previous charge (paragraph 6).

Thus there is one power stroke from each cylinder to every one revolution of the crankshaft.

For the sake of simplicity one cylinder only has been used as an example. The two cylinders of the "SCOTT" can really be looked upon as two separate Engines with separate crankcases. Each crankshaft is, of course, so coupled to the central flywheel that the cylinders fire at alternate half revolutions, thus delivering a perfectly even torque, whilst all reciprocating and revolving masses are balanced.

## II.—Inspection.

The pistons and rings can be partially examined without removing the cylinders, by taking off transfer port covers and exhaust port covers. At the same time the ports can be readily cleaned if necessary.

The cranks and connecting rods can be examined instantly by removing the crankcase inspection doors.

The water jackets need never be inspected, unless the rubber head joints have become damaged through running the engine without water. They are accessible, however, by removing the aluminium head.

## THE SCOTT ENGINE.

### The Six Phases of Operation in the Scott Two-Stroke Engine.

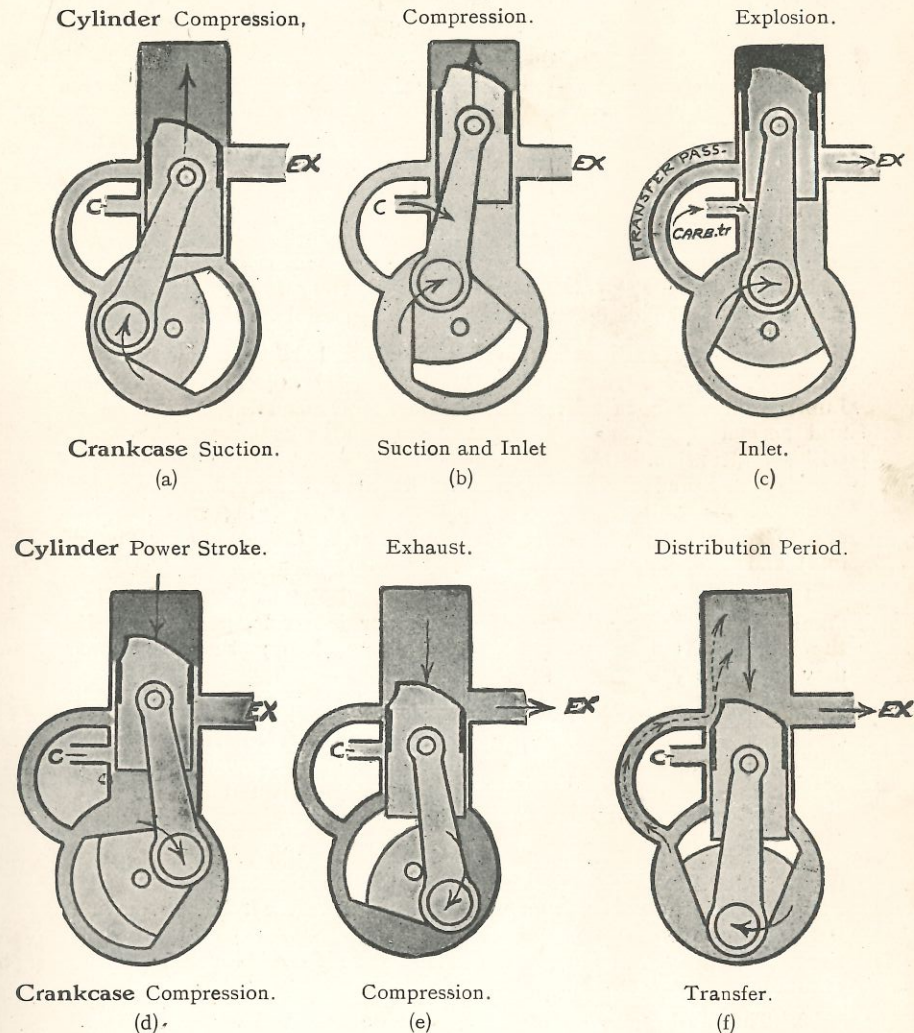

The depth of shading indicates degree of pressure in cylinder or crankcase; light shading indicates suction. These illustrations are, of course, purely diagrammatic.

### III.—Decarbonizing.

To obtain the best results and derive the greatest pleasure and satisfaction in riding, an engine must be kept reasonably clean internally, and the carbon deposit which gradually accumulates in the cylinders, etc., must be removed from time to time. No hard and fast rule can be laid down as to when this attention should be given because it depends so largely upon correct lubrication, petrol, carburation, etc. Symptoms indicating that an engine is due for decarbonization are progressive loss of power (particularly at high speeds), an excessive inclination to "knock" or "pink" when pulling hard, loss of compression (due to dirty or sticking piston rings) and an unnaturally silent exhaust (due to the carbon having reduced the effective area of the ports). Whilst it is possible with a Scott to continue running long after all these symptoms have developed, and though the risk of damage from so doing is remote, it is a practice that should be avoided as far as possible.

1. Normally such attention is not advised with a new Engine until it has been running for 1,200 to 2,000 miles, even though Lubrication has been on the liberal side. When an Engine is run-in and normal oiling adhered to, mileages of 3/5,000 may be covered without attention. In such cases the Ports and Piston Heads can be inspected and cleaned from time to time if desired (say every 2,000 miles). This is a very simple operation, it being only necessary to remove Transfer Port Covers, Exhaust Port Covers (or manifold) and Sparking Plugs.

It is highly important that Silencers and Exhaust Pipes be dismantled and cleaned thoroughly at regular intervals, particularly if the Engine has been subjected to an excess of oil; otherwise there may be a very serious loss of power.

2. When a complete decarbonization is to be carried out the cylinders must be removed (as described in the following section). All deposit must be scraped out of Combustion Chamber and wiped (or very carefully scraped) from the piston. (Aluminium Pistons are very easily damaged by careless handling).

Particular attention should be paid to the Cylinder Ports, Sparking Plug Orifices, and the sides of the Piston Head deflector. The Piston Rings should be removed and Carbon very carefully removed from the grooves. The inside of the Piston should also be cleaned if necessary, to prevent deposit formed there from falling into the crankcase.

3. The half-compression valves can be removed and cleaned if necessary. These valves rarely require regrinding. Care should be taken not to damage their retaining Lock Rings either upon removal or replacement. If a special Key is not used, the slotted heads should be tapped carefully with a copper punch.

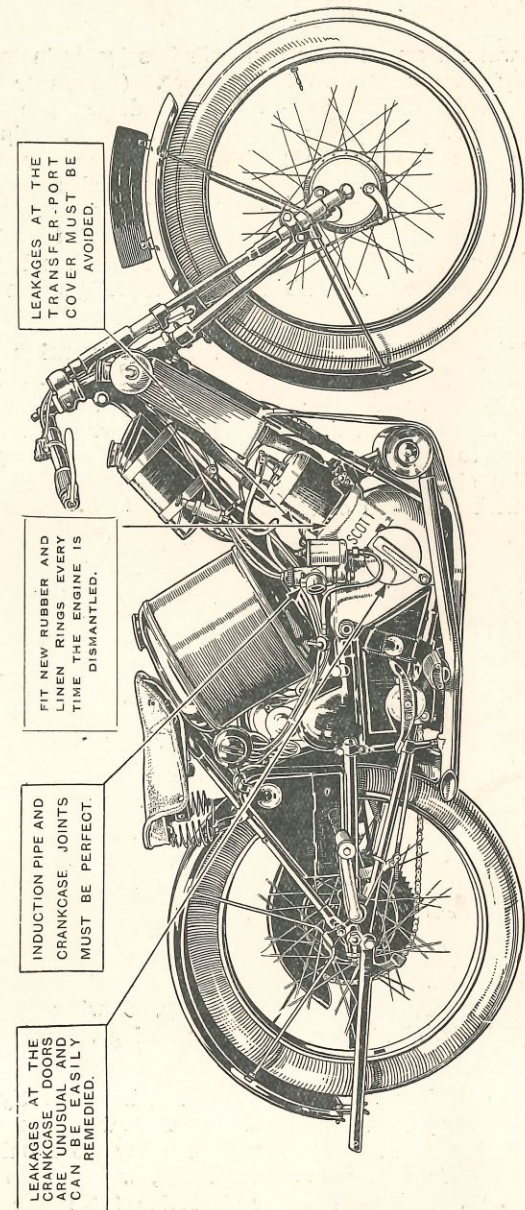

Points to remember when re-assembling the engine after an overhaul.

#### IV.—To Take Off Cylinders.

Drain out water from radiator and cylinders by drain tap. Take out sparking plugs and remove the silencer. (On Super Squirrels remove right hand exhaust port cover and detach the half-compression actuating rod). Take off transfer port covers. Slip off both rubber tube connections to the radiator and remove radiator by withdrawal of the three fixing bolts. Remove Cylinder holding down bolts, the heads of which will be found immediately above crankcase doors; these are threaded into the base of the cylinder casting. The cylinder casting can then be removed, but care should be taken first to see that both pistons are at the same height (half-way of the stroke).

If the cylinders are stuck, do not lever them by using a screw-driver between the jointing faces, as damage will result. The safest method is to replace the holding down bolts, screwing them in half way, when the heads can be tapped with a hammer or mallet. Care should be taken to tap each bolt in turn or preferably one of each side (diagonally) simultaneously, and then give the cylinders a tap on each side with the palm of the hand.

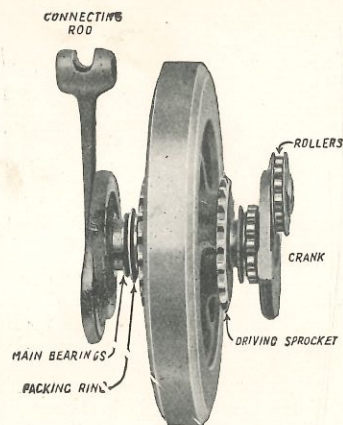

Flywheel and Crank Assembly, showing positions of big-end and main bearings, etc.

In replacing cylinders take great care in fitting correctly cylinder rubber base rings and linen jointing washers. New rubber rings and linen washers should invariably be used (they cost only a few coppers). Rubber rings should be fitted dry, whilst linen washers should be thinly coated with oil or Seccotine (gold size or other jointing materials should not be used).

As the cylinders are lowered into position the piston rings must be guided carefully into their grooves, to prevent the possibility of them riding over their stops. No extreme force must be exerted; the cylinders can be eased into position.

Cylinder holding down bolts should not be tightened more than can be done easily with a small spanner.

These bolts should be tightened in turn a small amount at a time, so that the cylinders may be drawn down uniformly.

All other joints should be made with scrupulous care, new Acreite packings being used if necessary for transfer port covers, induction pipe joint and crankcase doors. Great care should be taken in tightening the transfer port cover bolts, as undue tightening may distort the cover and fracture the crankcase. These should be fitted dry or merely coated with oil, and seccotine is quite unnecessary, providing the fitting is accurate.

#### V.—To take off Pistons and Connecting Rods.

Detach crankcase door strap, insert shaped end into slot on crankpin screw and twist round by means of a "tommy bar" through the hole. The right hand crank screw has a left hand thread and the left hand crank has a right hand thread, as stamped on the screws themselves. After removing the crankpin screw, the piston and rod can be withdrawn, by placing crankpin at top of stroke and tilting the rod sideways so that the bearing rollers fall away. On all the latest type engines it will be noticed that the crankcase door opening is enlarged at one point; the crank pin screw can only be removed when the crank is turned to this point. There are 12 rollers and these should be collected in the hand as they fall out. Before re-assembly it should be made certain that no roller is accidentally left in the crankcase, whilst rollers from each side should not be mixed. If difficulty is experienced in slackening the crankpin screws, tap the end of crankcase door strap whilst it is in position in the slot, at the same time attempting to unscrew.

**Note.**—It is preferable to slacken the crankpin before the cylinders are lifted (when the engine can be held from turning by engaging gear), but should this not have been done, the Engine may be prevented from turning by packing carefully pieces of wood between bottoms of both pistons and crankcase face.

To detach pistons from Connecting Rods, it is only necessary to push or tap out the gudgeon pins; they must be pushed from the smaller-diameter end.

#### VI.—Re-Bushing Connecting Rod.

1. The Gudgeon Pin Bush can be renewed by any average mechanic. It is fixed into position by a 5 B.A. Screw which must

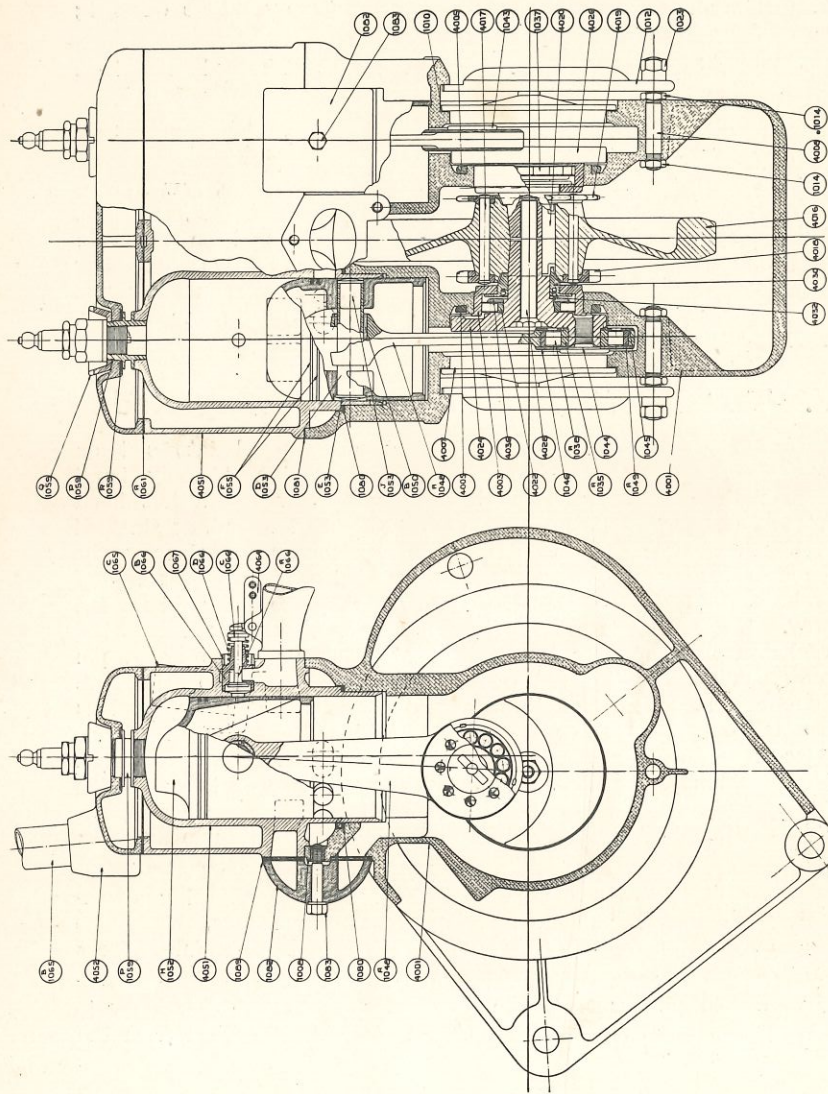

The 596 cc. Flying Squirrel Engine, in end and side section.  
The part-numbers correspond to those in the Spare-parts List.

## THE SCOTT ENGINE.

first be removed, after which the bush can be driven out. A new one is then pressed into position by means of a vice; it should only be eased on the outside with emerycloth if absolutely necessary. The bush must then be drilled and tapped to take the screw (it being advisable to use a new one) and this should be prevented from slackening by centre-punching the edge of the head. The top centre portion of the bush can then be cut away and trimmed to conform with the shape of the small end. Oil grooves similar to those in the old bush should be cut, care being taken that these lead from the centre cut away portion (which acts as an oil collector) towards each end, but not quite reaching the extreme edge. Finally the bush should be carefully fitted to the gudgeon pin, it being supplied a trifle under size. This is best done by accurate scraping or the use of a reamer.

2. **Big End Bushes.** These are made from a special chrome steel, hardened and ground. They are not supplied separately (except in very special circumstances, such as for overseas requirements, and then only when accurate grinding facilities are available). Connecting rods must be returned to Works for rebushing.

Over-size engine rollers are not, and never have been, supplied, as the practice of using them is wrong. Owing to the explosion force, wear does not take place evenly on the bushes, and therefore when the bearings appear slack even with a new set of standard rollers, nothing but re-bushing will effectively remedy matters.

## VII.—Piston Rings.

Use only "SCOTT" Rings.

1. **Fitting New Piston Rings.** Rings are supplied a trifle over size so that they can be fitted accurately. When ordering replacements it is advisable to give accurate measurements (particularly depth) or to return an old one as sample. Each ring should be carefully tried in its groove, not by fitting it, but by rolling it round the piston. If at all tight it should be carefully rubbed on a sheet of finest emery laid upon a perfectly flat surface (such as plate glass) until it is an easy fit. Care should be taken when fitting the ring, that the side so eased be fitted uppermost.

Each ring should then be tried alone in its respective cylinder, and the gap should be measured as accurately as possible. This should be approximately 10 thousandths of an inch in excess of the width of the piston ring stop. The most accurate method of doing this is to use a feeler gauge in conjunction with a piece of metal ground to the same size as a stop. Alternately the piston ring gap can be increased (by accurate filing) to approximately the correct amount, when the ring may be fitted to the piston and tried in the cylinder. Under no circumstances exert force to enter a new ring so fitted; also, when trying a piston in its cylinder do not

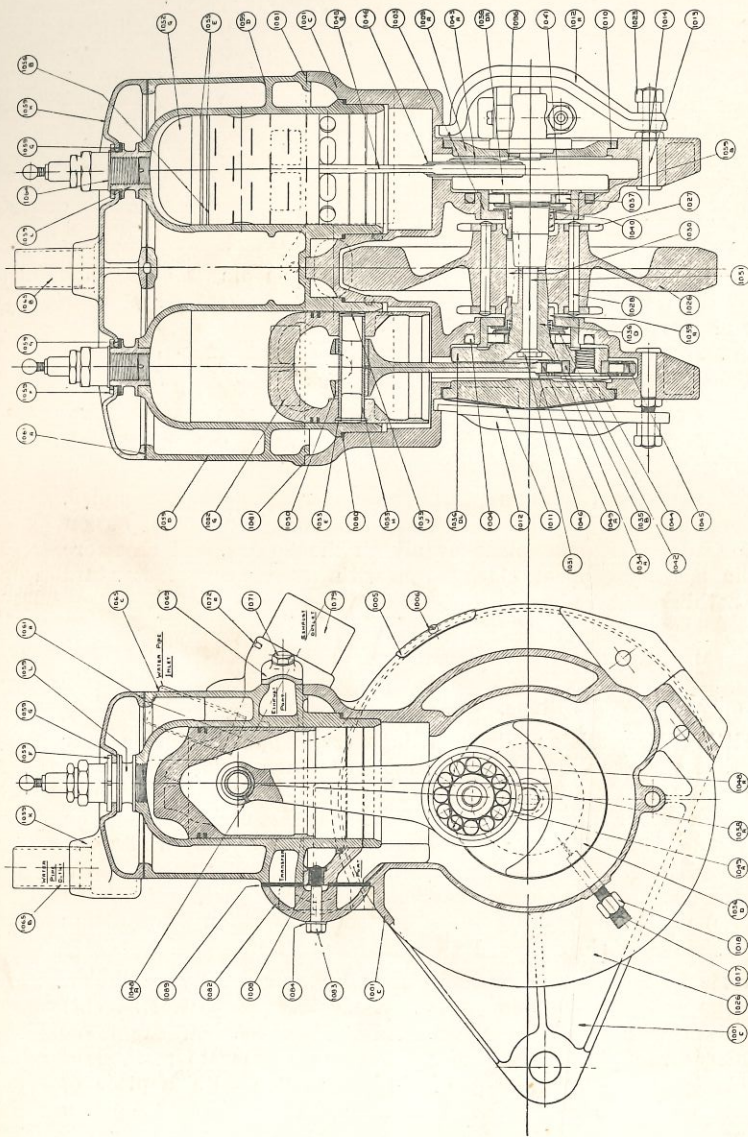

Composite drawing of Super Squirrel Engine, 1926 and later.  
In present models, the oil pump occupies another position.

## THE SCOTT ENGINE.

push it to the extreme top or the rings may become jammed (a wad of paper in the cylinder head will avoid risk of this). The actual clearance between piston ring and stop can then be inspected and measured through one of the cylinder ports.

With an old Engine it must be borne in mind that the cylinders wear appreciably more at the middle of the stroke than at the bottom. Therefore a ring that is on the tight side at the base of the cylinder may be reasonably correct under working conditions. In extreme cases of wear, however, the cylinders should be re-ground, oversize pistons and rings being, of course, used.

When fitting rings it should be noted that the base of the stop must not be allowed to foul the ring, when depressed to be flush with the piston diameter. New rings are already ground to give this clearance, but may be touched with a file if thought to be necessary.

### VIII.—Crankshaft, Main Bearings and Packing Gland.

1. We do not advise the removal of the crankshafts by any but expert hands. It is, however, a perfectly straightforward matter.

First of all unscrew **left hand threaded** lock nut, at the centre of the right hand crank (using a stout box spanner). Then partially unscrew bolt head on left hand crank, two to three turns (right hand thread). By means of a smart blow on the bolt head, the right hand crank may then be dislodged from its taper fit in the flywheel. The bolt can then be further unscrewed and withdrawn, allowing the right hand crank to be removed complete with rollers and packing gland (there are 13 rollers in each main bearing of Super Squirrel Engines, and 15 in the Flying Squirrel Type) Remember warning regarding big end rollers.

The left hand crank can then be similarly dislodged by inserting a steel bar of as large a diameter as will **pass through** the flywheel centre, giving it another smart blow.

The greatest care must be taken in replacing the cranks. The rollers are most easily held in position by grease (such as vaseline) and each must be down on the bearing, as otherwise difficulty will be experienced in getting them all into the crankcase cup. Care should be exercised in replacing the packing gland, the tongue of which must engage with the key-way in the flywheel.

After the crank bolt is screwed up each crank should be driven into the flywheel by using a hammer and a tubular punch (three smart blows only are best). Whenever **hammering up a crank, the other one must have been put already in position and a solid mass brought to bear against it**, so that the force of the blow may not be transferred by the flywheel to the crankcase cup.

## THE SCOTT ENGINE.

Each crank should be knocked up in turn and the crank bolt tightened up a little more throughout the procedure.

The cranks **must** be driven up absolutely solid to the flywheel, as otherwise undue turning stresses are put upon the key, which may shear in consequence.

When re-assembling use a new crankshaft bolt and nut if the threads of the old one are in the slightest damaged. Do not over-tighten the bolt or stretching will occur. Over the left hand thread nut the bolt should be lightly riveted, to prevent any chance of it working loose. The nut may require to be thinned down a little in order to do this, and also to prevent it fouling the large hole roller plate of the big end bearing; this roller plate must seat properly on the ground face of the crank and still clear the crank bolt nut.

2. **Re-bushing Cranks.** Crank pin and main bearing bushes are also of special hardened chrome steel, ground after fitting. They are, therefore, not supplied separately (see previous remarks on big end bushes). Cranks must be returned to Works for re-bushing.

3. **Crankcase Cups** also can be fitted only at Works. No attempt should be made to remove them. If they become misplaced, the oil ports will not register correctly and certain trouble will result.

### IX.—To take Engine out of Frame.

With Super Squirrel Models proceed as follows :—

Remove Radiator and connections.

Detach oil pipes and petrol pipe.

Remove inlet pipe complete with carburetter.

Disconnect Engine-Gear Chains.

Take off exhaust port covers, releasing half-compression actuating rod.

Detach silencer attachments and slip silencer down.

Withdraw the Engine fixing bolts.

After sliding the Engine forward a little, it can be lifted out of the frame.

During an Engine overhaul, the opportunity should be taken of cleaning out the short oil union pipes that are screwed into the crankcase, as foreign matter is liable to accumulate therein.

When replacing the Engine, tighten up Engine bolts securely and time magneto as directed elsewhere.

**Flying Squirrel Models.**

Place a suitable support beneath the crankcase.

Detach Plug Leads. Take off Magneto Chain Guard.

## THE SCOTT ENGINE.

Disconnect Engine-Gear Chain and Engine Magneto Chain.

Remove Carburetter Slides and Cables. On T.T. Replicas, detach each cylinder wall oil pipes.

Take off Exhaust Pipes or Silencer.

Detach half-compression spring hook from crankcase.

Disconnect clutch cable from top crankcase distance piece.

Remove rear brake pedal to avoid scratching cylinders when sliding Engine out of frame.

Slacken off the three engine fixing bolts which pass through the engine and frame, and then take out the bottom bolts first, and the top bolt last.

The weight of the engine is then taken on the underneath support.

Move the front wheel into a suitable position, and slide out the engine from the front of the frame.

Replace engine in reverse order.

The Undershield will be left supported by its rear fixing bolts.

**To remove Flywheel.** This can only be done after the cranks have been removed. In replacing flywheel see that it is put back the same way, which is such that the fingers of the right hand fall naturally into the groove of the rim.

### X.—Engine Sprockets.

These are made from case-hardened steel, and having a comparatively large number of teeth (20) they last almost indefinitely. However, should it become necessary to replace them, it will be noticed that they are fixed by four long  $\frac{1}{4}$  in. rivets passing through bosses on flywheel web. The sprockets can be removed by drilling out the countersunk ends of the rivets on one side and driving them out with a punch. It must be remembered that **only 20T Sprockets** must be fitted to the Engine, as the ratio of the magneto drive is dependent upon the size.

### XI.—Half Compression Valves.

1. **The function of these Valves** is to reduce the compression in the Cylinders by permitting access to the Exhaust pipe through an additional port placed above the main exhaust port. When this is open the effective stroke of the Piston is decreased, since compression can then only begin when the Piston has travelled far enough to close off this extra port—resulting in about half the normal Cylinder compression.

Since these Valves are situated in the lower part of the Cylinders they are not exposed to the extreme temperature that Valves in

## THE SCOTT ENGINE.

4-stroke Engines (or other 2-stroke Engines) need withstand. It is therefore, extremely unlikely for them to give trouble.

2. The operating rod should be so set that both Valves bed down upon their seats, and to ensure this a clearance of 1/16th in. can be allowed between the Valve stem heads and the Tappet Arms formed on the actuating rod. Adjustment for the amount of lift is provided at the frame anchorage of the Bowden Cable or on the cable itself.

The end of the inner cable is connected through the medium of a stiff tension spring to the lever operating the half-compression rod. The purpose of this spring is to permit a further movement of the hand lever after the valves are fully opened, in order that the Magneto cut-out switch can be brought into operation after the compression is thus reduced. Care should be taken not to confuse the aforementioned spring with the return spring, should they be detached. The return spring is longer and lighter than the other.

### XII.—Transfer Ports.

1. The port covers are easily removed by unscrewing the single central holding bolts. These should not be screwed up more than can be done quite easily with a small spanner, since undue strain upon them is likely to distort the Aluminium Casting.

2. Transfer Gauzes. The metallic gauzes which are inserted between the port cover faces and the cylinder and crank case port faces are for the purpose of preventing back firing into the crankcase, as might occur with a weak mixture or ignition too much retarded. (Gauzes are not fitted as standard to 498 c.c. Engines. They can be fitted if desired but a slight drop in maximum speed and power will result). Provided the carburetter is not very seriously out of adjustment, there is little likelihood of these gauzes becoming dirty, but should they do so, new ones must be fitted if the old ones cannot easily be cleaned. The cooling influence of the adjacent water jacket prevents them from becoming burned.

When re-fitting gauzes, care should be exercised to see that they register with the ports, as also the Acrite packings between two of which each gauze should be placed. This is facilitated by ledges formed on both the crankcase and cylinder faces.

If difficulty is experienced in obtaining a perfect joint at this point the Acrite packings may be smeared with seccotine.

### XIII.—Plugs.

As a rule plugs capable of standing oil are not suitable for standing heat, and vice-versa; it is important, therefore, to use the type of plug most suitable for your purpose. From our own experience we recommend the following:—

## THE SCOTT ENGINE.

For fast touring: LODGE H.1, K.L.G. H.S.3, or A.C. 114Q.

For town work and general purposes: CHAMPION 13.

For racing: K.L.G.268 or A.C. 115Q.

Care should be taken when fitting a new plug to make sure it is not longer in the reach than  $\frac{3}{4}$  in., as with a plug of too long a reach damage to the piston is likely to occur.

### XIV.—Engine Defects.

Assuming that both carburetter and magneto are functioning correctly, the efficiency of the Engine primarily depends upon the following:—

Good cylinder compression                      Good crankcase compression.  
Correct timing of magneto.                      Absence of airleaks.                      Freeness of bearings and working surfaces.                      Correct and equal lubrication in both sides.

Cylinder compression can be tested by standing upon the kick-starter pedal, or by engaging high gear and pulling the back wheel round with the machine on the stand. Each cylinder should offer considerable and equal resistance. Compression may not appear good immediately after an Engine has been decarbonized, particularly if new piston rings have been fitted, but this should rapidly become normal after a little use.

Defective Cylinder Compression may be due to faulty or broken piston rings, shortage of oil, stuck up half-compression valves or leakage from the sparking plugs.

Crankcase Compression can be tested by removing the sparking plugs, engaging high gear and turning the Engine round sharply by means of the back wheel. There should be a distinct "pop" at each half revolution (suggestive of a cork being withdrawn from a bottle). Weakness of compression in either crankcase can be detected by the nature of this sound.

Crankcase leakage may be due to badly fitting crankcase doors or transfer ports. Faulty piston rings or want of oil will also impair crankcase as well as cylinder compression.

It is highly improbable that leakage will ever occur from the crankshaft glands, as all normal wear is automatically taken up, whilst the hardened steel faces are constantly lubricated by the incoming fresh oil. It is just possible, however, for a gland to stick if foreign matter has been allowed to get into the crankcase or lubricant. A sticking gland can readily be remedied by a few light blows on one or both cranks.

Any point at which crankcase leakage occurs can usually be traced by looking for signs of oil leakage. A thorough test can, however, be carried out, if desired, by filling the crankcase with

## THE SCOTT ENGINE.

oily paraffin and noticing where it escapes upon turning the Engine until the maximum crankcase compression is exerted upon it. Naturally, after such a test the crankcase must be drained dry by means of an oil squirt, and replenished with oil.

To test for air leaks the best method is to run the Engine slowly and with a petrol injector squirt spirit round all the joints. Any leaks will be shown by sudden variation of Engine speed.

Firing on One Cylinder can readily be detected by alternately detaching Plug wires when Engine is running and noting on which cylinder the Engine is firing. The cause of the trouble in the faulty cylinder will most likely be found already mentioned under "Starting Difficulties." (See page 10).

Owing to the smoothness of running of the Scott Engine it is difficult for the uninitiated to tell whether the engine is firing on both cylinders or not, except by the unusual loss of power when only one is firing.

Loss of power can often be traced to partial choking of the silencer or exhaust pipe with burnt oil and carbon. These should be thoroughly cleaned periodically.

A sudden loss of power, assuming that the Engine is not running short of oil, can often be traced to partial choking of the carburetter jet or petrol feed pipe, it usually being accompanied by pronounced "knocking."

Plug Trouble sometimes shows itself by puzzling symptoms suggestive of other causes, and it is a wise plan to test the Engine with a new pair (of course, of a suitable Type) before time is wasted upon locking for other troubles.

The Scott Gold Medal Silencer.

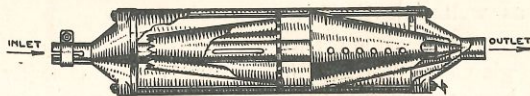

Part Sectional View showing internal construction.

## THE SCOTT TWO-SPEED GEAR.

(Super Squirrel Models).

### I.—Its Action.

The two-speed gear consists of two selective Friction Clutches mounted side by side, which can alternatively be thrown into action by the rocking motion of the gear pedal.

There are no gear wheels.

All parts are made from special alloy steel stampings—case hardened and ground to limit gauge. Since no malleable iron castings, phosphor bronze, or other soft metal wearing parts are used, the gear is practically impervious to clutch slipping, provided it is kept lubricated.

The hub contains an internal central ball bearing thrust block, pivoted by means of screws passing through slots in the hub, to a ring-shaped thrust lever, so that this lever may be moved backwards and forwards during the rotation of the hub by means of a sliding rod passing through the hollow spindle on which the hub revolves.

The movement of the rod is obtained by the rocking motion of the gear pedal attached to the quick thread drum over the internal drum which is fixed in a definite position to the right-hand frame lug.

The hardened steel gear drums are each mounted on two ball races on each side of the hub, and are held on by screwed lock rings at each end.

The low gear drum is fitted with a large sprocket and the high gear drum with a smaller one, and both sprockets are directly driven by a pair of chains so that they are always in gear with the engine and revolve at different speeds, according to the variation in size and number of teeth of the sprockets.

Two hardened steel split rings are supported on side plates, which are mounted on the hub, so that the rings lie side by side within the drums.

The opened ends of these rings are formed so as to present a slightly tapered slot, and are driven round with the hub by the thrust lever, one end of which has a tongue fitting into a recess on each ring, while the other end carries a pair of rollers which normally lie in between the two tapered slots.

These split rings can, therefore, be expanded by the sideways movement of the thrust lever, causing the rollers to enter the tapered slot on either ring—thus expanding the ring and bringing it into frictional contact with the inner surface of the drum surrounding it.

## THE SCOTT TWO-SPEED GEAR.

In the neutral (midway) position of the thrust lever and rollers neither ring is expanded, so that both rings run free, out of contact with the drums.

When the engine is started up the hub is stationary with the back wheel but the drums revolve with the engine, on the ball-bearings between them and the hub, at different speeds—the low gear drum (with the large sprocket) running about half the speed of the high gear drum (with the smaller sprocket).

Upon rocking the gear pedal backwards, the thrust lever and rollers are moved so as to expand the split ring within the low gear drum until the whole of its frictional surface is brought into contact with the inner surface of the drum, causing its gradual engagement until the drum and hub move together as one, and the drive is transmitted to the back wheel. At the same time the high gear drum runs idle with the hub, but at a higher speed.

Upon rocking the gear pedal forward, the low gear clutch is disengaged, and the high gear drum is thrown into action in the same way, whilst the low gear drum runs idle with the hub, but at a slower speed.

Consequently the drive is always transmitted through one chain at a time whilst the other runs idle.

The pedal is retained in position by the action of an automatic grip device which is released when the pedal is placed midway or horizontal so that the "free-engine" position can be easily found by the slack feel of the pedal in contrast to the increasing stiffness of movement as the pedal is pressed over to engage either clutch. By this means the exact position, and corresponding engagement of the clutches can be gauged to a nicety by the "feel" of the pedal.

Since the magneto is driven from the high gear drum it is impossible to run the machine with the high gear chain removed. It is, however, possible for racing purposes to run without the low gear chain.

### II.—To remove Gear (Two-Speed).

The complete two-speed gear can be removed from the frame without undoing the engine chains. After removing the side-shields and under-shield, take off the rear driving chain, and unscrew and remove the bolt passing through the oil pipe lug. Disconnect the kickstarter chain (rear end), remove footrests and detach left hand gear lug. Then remove the gear pedal and proceed to dismantle in the following order:  $\frac{1}{4}$ -inch shoulder nut, together with spring washer, outer quick thread drum and friction clip,  $\frac{1}{4}$ -inch washers on end of sliding shaft,  $\frac{5}{8}$ -inch hexagon nut on end of spindle, internal

## Components of the Two-Speed Gear.

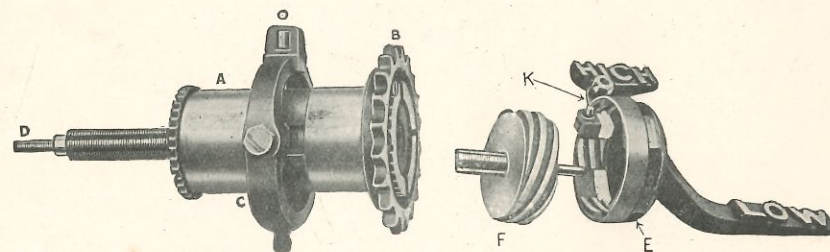

Gear Hub Assembly with Driving Sprocket.

Gear Pedal and Quick-thread Drums

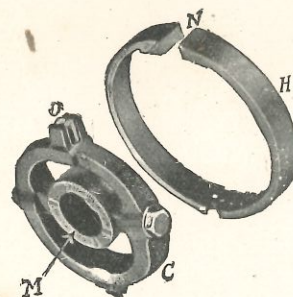

Thrust Lever and Expanding Ring.

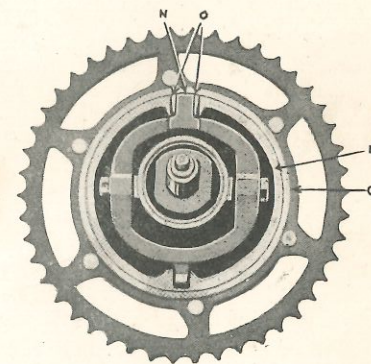

Gear in Part Section.

- A—Hub,
- B—Driving Sprocket.
- C—Thrust Lever.
- D—Thrust Rod.
- E—Outer Quick-thread Drum.
- F—Inner Quick-thread Drum.

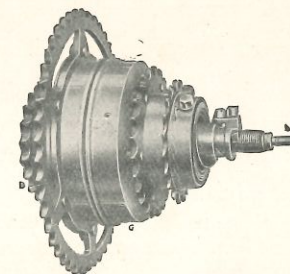

The Complete Gear Assembly.

- G—Gear Drum.
- H—Expanding Ring,
- K—Pedal Friction-grip Strap.
- M—Centre Thrust Block
- N—Tapered Slot.
- O—Thrust Rollers.



## The Kickstarter of the Two-Speed Gear.

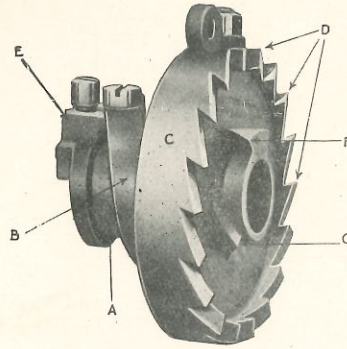

A—Kickstarter Boss or Sleeve.  
 B—Scroll Spring.  
 C—Ratchet Drum.  
 D—Ratchet Teeth.  
 E—Spring Retainer.

F—Fixed Lug (or Cam on  
 K.S, Sleeve).  
 F—Cam or Lug on Ratchet  
 Drum.

## The Scott Two-Speed Gear.

As it appears in the frame when Gear Shields are removed.

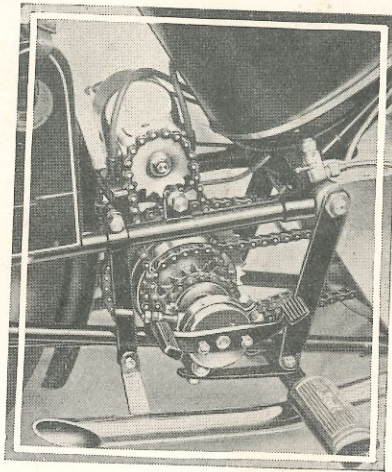

This photograph shows the accessible adjustments provided for Gear and Magneto Chains. For the sake of clearness, the oil pump has been omitted.

## THE SCOTT TWO-SPEED GEAR.

(cones should be tight up against shoulders on spindle)—no play but perfectly free. The adjustment is provided by different thicknesses of washers which fit the spindle (short thread end).

After replacing the sprocket and the lock ring, the hub can be held firmly, as becomes necessary, when replacing the drums, etc., and tightening up the hub lock rings.

Take care to replace the parts in correct way, and after replacement of the gear in the frame, see that the chains are running in true alignment. The magneto will require to be re-timed whenever the high-gear chain is removed.

## V.—Two-Speed Gear Defects.

1. A **Slipping Clutch** is due to insufficient grip of expanding ring on the drum.

The pedal is retained in either the forward or backward position by the friction grip provided by the strap (K) on the outer quick thread drum, to which the pedal is attached. (See illustration). To increase this grip tighten the bolt and nut securing this strap.

If slipping in either gear can be prevented by applying foot pressure to the pedal it proves that the gear itself is in working order, and all that is necessary is adjustment of the quick thread drum strap. The careful adjustment of this strap makes a great difference to the sweetness and certainty of gear engagement. The quick thread drums should be lubricated periodically, not with oil, but with paraffin.

2. The thin  $\frac{1}{4}$ -inch washers on the thrust rod are for the purpose of adjusting the pedal position.

Increasing the number will result in the engagement of low gear with less movement of the pedal, whilst decreasing the number will allow the pedal to go further down in low gear position. This adjustment will also alter the pedal position for engagement of high gear (but the opposite way), the amount of movement through neutral remaining constant. This neutral movement is determined by the length of the sleeve nut and thickness of spring washer. No attempt should be made to alter either of these or to fit parts other than standard. This spring washer should not be fully compressed even when the sleeve-nut is tight, i.e., the outer drum must be quite free to rotate without any tendency to twist the thrust rod (which merely slides in and out); otherwise a fracture may result. Likewise do not exert great pressure on the sleeve-nut when tightening up; remember it is only a  $\frac{1}{4}$ -inch diameter thread.

3. **Over-size thrust rollers** can be fitted to take up excessive wear of rings and drums, but before resorting to such a measure

## THE SCOTT TWO-SPEED GEAR.

all unnecessary end play in the centre thrust races, etc., should be eliminated, as this is a more likely cause of excessive pedal movement.

4. **Excessive side play of the drums** can be taken up by removing the high gear drum and replacing the distance washer between it and the expanding ring side plate by a slightly thicker one (a variety is supplied).

This must, of course, be checked whilst the Gear is in neutral and both drums are free. If side play of more than 1/16th of an inch is still evident, it will be necessary to fit a similar oversize washer to the low gear side.

5. **Fierce action of Clutch** is due to want of oil. In an emergency oil may be injected through the holes provided on the outside of the drums as well as by the usual means.

## VI.—The Kickstarter (Two-Speed Models).

1. This consists of a foot lever working from the back fork lug with a bell crank arm connected by rod and chain to a ratchet drum mounted on the right-hand side of the two-speed gear, inside the frame lug.

The ratchet drum is mounted on a boss, which fits over the gear spindle. The drum contains a scroll spring, the inner end of which is fixed to the centre of the drum, whilst the outer end is anchored by means of the spring retainer to the boss.

The side facing the two-speed gear is formed with ratchet teeth which engage with a ratchet ring fixed on the end of the high-gear drum.

The action of the scroll spring is to twist round the ratchet drum so as to draw back the chain and rod attached to the starting lever, and also to force the drum sideways towards the gear ratchet, so that the ratchet teeth are engaged—but as the starting pedal is brought back to its normal position by the rotation of the drum, a cam is brought into contact with a fixed lug, formed on the end of the boss, and the drum is forced back so that its ratchet teeth are thrown out of engagement with the gear ratchet ring.

2. **To adjust Kickstarter (2-Speed Models).** The ratchet device with spring and boss forms a separate unit (the assembly can be supplied ready to slip on to the two-speed gear shaft). This can easily be removed. Proceed as follows:—

Detach Kickstarter chain from rod.

Take off gear pedal and quick thread drums.

Release clamp bolt under left hand gear lug, and slacken off the oil pipe and the two nuts on the chain tensioning device at that side.

## THE SCOTT TWO-SPEED GEAR.

The gear can then be lifted on the starter side without disturbing the right hand lug.

When fitting the assembly, take out the sparking plugs so that the engine may be rotated easily. Slide the assembly on to the gear spindle and refit the gear into the frame lug. Loop a length of cord through the starter chain anchor and wind the cord round the ratchet in a clockwise direction about  $1\frac{1}{4}$  turns bringing the loose end to the rear of machine. Engage high gear and simultaneously pull the cord and turn the rear wheel in a forward direction until the anchor is within one eighth of a revolution from the top position. The ratchet is then held in this position by wedging a screwdriver between it and the frame. The spring being now wound up, the starter chain can be attached to the anchor (and to the rod if it is not already attached thereto) and the screwdriver withdrawn.

During this operation on no account must rear wheel be turned in a reverse direction to above, otherwise damage will be done to kickstarter spring.

Adjustment is made by screwing up the link roller on the thread of the rod, so that the ratchets are thrown out of action on the return stroke of the starting pedal.

The device bearing should be oiled regularly to avoid sticking (see "Lubrication").

If the ratchet will not come out of mesh no matter how the rod is adjusted, the starter device must be taken off the spindle and a thin 5/8th-inch washer slipped on the spindle up against the main bearing cone, and the device replaced. This will throw the device further away from the high gear drum, and the ratchets will consequently be clear. The above washer is similar to those used for adjustment of the gear main bearing cones.

3. **Kickstarter Defects (2-speed Models).** A slipping ratchet can be caused by the following:—

- (1) Drum sticking on boss through dirt or want of oil. Squirt paraffin over it and thoroughly lubricate.
- (2) Defective Spring. Whether it has become weak or partially broken a new one should be fitted.
- (3) Wear on ratchet teeth caused by improper setting of ratchet drum. The teeth should be well clear of each other when the starter is out of action.
- (4) Excessive side play in gear allowing displacement of ratchet ring. This should be remedied, as it denotes serious wear or mal-adjustment.



### III.—To Dismantle Gear Box.

The Gear Box can be completely dismantled without removal from the frame. Proceed as follows:—

Having removed the gear shields, disconnect both chains, remove driving sprocket bracket by detaching the nuts of the two fixing bolts. The sprocket forms a unit with the bracket and can be slid straight off the splined shaft.

Remove kickstarter cover screw and cover, which leaves the spring in position. Grip the top portion of the spring with a pair of pliers, withdraw from anchor pin, gripping pliers firmly while spring is allowed to unwind, then the spring may be detached from the centre pin. Remove kickstarter cap which has a left-hand thread. Remove kickstarter stop by detaching nut. Then the kickstarter pedal, after being rotated in a clockwise direction until it is pointing forward slightly, can be pulled off.

The central ratchet bolt and washer can now be removed (right hand thread), after which the ratchet may be withdrawn by inserting a screwdriver behind, through the slot in the kickstarter boss. Remove the remaining three gear box cover sleeve nuts, which will leave the cover located by three dowel pins. Before removing the cover, the joint should be broken by applying smart blows with a block of wood around the edge of the lid, or if the driving sprocket bracket has been removed, by smart blows on the end of the main shaft. Under no circumstances should a sharp instrument be inserted between the joint faces.

Place a receptacle to catch the oil, and withdraw cover by a straight pull, continuing to tap it slightly at the same time, if it sticks.

It is possible to withdraw at the same time the middle and low gear wheel assembly, and also the main shaft, but if the cover be removed alone, these parts may be withdrawn separately. In the latter case proceed as follows, after removal of cover:—

First withdraw layshaft, i.e., the rear shaft. If it does not pull out easily, a spanner may be fitted to the square and locked in position by replacing the ratchet bolt and washer. A firm pull may then be exerted upon the shaft, whilst it can be eased out by rocking it slightly. Whilst removing the layshaft, the middle and low gear wheel assembly can be slipped off the main shaft. The main shaft can then be drawn straight out, which allows the sliding dog to fall free. Take care to collect the operation fork shoes, which may drop out of the fork.

The high gear wheel can only be removed after dismantling the clutch. Before re-assembling make sure that the gear box is perfectly clean internally.

### IV.—The Three-Speed Clutch.

The Clutch is of the dry multi-plate asbestos-insert type, alternate plates transmitting the drive to those between them.

The whole of the Clutch can be dismantled without disturbing the gear box. First detach the Driving Sprocket with its bracket, and then disconnect the engine chain. The hexagon headed screws that carry the clutch springs may now be removed together with the springs. The clutch body and plates may now be drawn away from the box, care being taken to collect the 30 Rollers that will fall away from the Clutch Race.

The Clutch operating mechanism is between the clutch race plate and the gear box. It rarely becomes necessary to dismantle this, but in order to do so, the Race Plate locking nut must be detached, the edge of its locking washer being first prised up from the flat face of the nut. When removing this nut, the Race Plate must be prevented from rotating, and this is best done by wedging a bar between two of its studs. Parts are then removed as follows:—

Race Plate, Ball Thrust Race, Lever Return Spring and Clutch Lever.

In re-assembling, see that the Lever is replaced with its hardened steel ring facing outwards, and that it is engaged with its correct thread, i.e., so that it points vertically upwards when midway in its travel.

The Bronze Worm upon which the lever works, is a press fit upon the gear box spigot, being positioned by two flats machined thereon.

To re-assemble the Clutch, first put the Race Plate into position and replace locking washer and nut. If the locking washer has become damaged, it should be turned to a fresh position. The locking nut must be screwed up dead tight, whilst the Race Plate is held as when dismantling, and finally the locking washer must be flattened over the nut.

Next, the Rollers are replaced in their cage. They should be smeared with grease sufficiently stiff to hold them in position. The Sprocket assembly can now be pressed over the Rollers. Plates are then assembled in the following order:—

1—A small plate. 2—A plate with inserts. Then followed by two similar groups, finishing with the end plate. The springs should now be replaced, care being taken to tighten them up in pairs diametrically opposite one another.

If the Clutch Plates only are to be inspected the Sprocket assembly must be carefully held in position when they are withdrawn, to prevent the roller race at the back thereof being disturbed and the rollers falling out. The engine chain need not be detached.

### V.—To Alter Gear Ratios. (Three-Speed Models).

The ratio of the final drive can easily be altered (thus affecting each gear) by changing the driving sprocket. This is supplied in the following sizes :—

16, 17, 18, 19, 20, 21, 22 teeth.

The operator is as follows :—

Remove bearing end plate which screws out from bearing bracket. Then unscrew sprocket lock nut which will be found inside. Remove bracket complete when the sprocket may be drawn off, or carefully tapped out.

### VI.—Kickstarter Defects. (Three-Speed Models).

A **Slipping Ratchet** is usually due to dirt, want of oil or a defective pawl spring. This can be remedied by cleaning, lubricating or fitting a new spring.

Similar trouble can be experienced if the ratchet teeth have become chipped. This is invariably due to allowing the Engine to back-fire when starting, and care should be exercised always to start with the ignition sufficiently retarded. If the teeth are badly chipped the ratchet must be renewed.

It sometimes happens after a back-fire when kickstarting that the starter becomes temporarily inoperative. This is caused through the starter pawl being thrown out beyond its normal position and getting above the pawl-spring (acting in the nature of a "safety valve," it thus avoids the risk of damage from back fires). It is easily put right again by lifting the spring by means of a screw driver until the pawl can be dropped under its free end; the spring will then return to its normal position on the outside of the pawl.

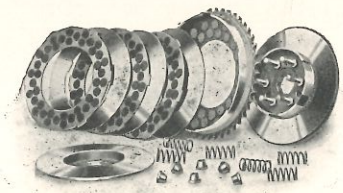

Components of the Scott Multi-plate insert-type Clutch.

## CHAINS.

### I.—To Adjust Engine Chains on Two-Speed Models.

Engine chains are adjusted by sliding the gear backward or forward along the frame tubes, having first slackened the bolts under both gear lugs several turns. Screw adjusters are provided behind each gear lug, which makes the operation very simple.

When making adjustment always move each side a little at a time alternately.

It is of much more importance to have the gear and chains in perfect alignment than to get both chains in equal tension. This can be checked by measuring the distance from the gear spindle to the crankcase door strap clamping bolt which should be the same to within an eighth of an inch on both sides.

**Note.**—If the measurement is done with an ordinary rule, and not a special gauge, allowance should be made for the angularity of the distance between centres on the **Pedal side**. The measurement of this side should, therefore, be one-eighth to three-sixteenths of an inch more than the other side measurement that can be taken parallel to the frame tubes.

Correct adjustment is when the tighter of the two chains can be lifted three-eighths of an inch from its normal position half-way between the sprockets, and this at its tightest point. The gear lugs must, of course, be clamped again to the frame tubes, after which the Engine should be turned slowly and the adjustment finally checked. It is better to run with chains too slack than too tight.

### II.—To Adjust Driving Chain (All Models).

This must always be adjusted in conjunction with (or after) gear chains. Screw adjusters are provided on the rear frame lugs, but before these are used the spindle nuts must be slackened, as also the brake anchor bolt. The chain should be adjusted to allow approximately half an inch movement at its tightest point, whilst the wheel must be kept in alignment. The soundest method of testing alignment is to place a perfectly straight bar against the sides of both wheels, as high as the mudguards, etc., will allow. The wheels are correctly aligned if it is possible to hold the bar in contact with the wheels at the four points where it crosses the rims. Alternatively a piece of string may be stretched horizontally and parallel to the machine, measurements to rims being taken therefrom.

### III.—To Adjust Engine Chain (Three-Speed Models).

This is adjusted by sliding the gear box along its guide-rails on the aluminium tray; a draw bolt to facilitate this is provided.

Slacken the two fixing bolts which protrude through the bottom of the tray. Also slacken the two bolts carrying driving sprocket outside bearing bracket (at left side of aluminium tray). When tightening up, the driving side must be done last.

After moving the gear-box, always check the engagement of gears and adjust if found necessary.

### IV.—To Adjust Magneto Chain. (Two-Speed Models).

This is adjusted by slackening the three bolts attaching the platform to the frame. The front of the platform is then rocked in the desired direction and the platform again clamped.

### V.—To Adjust Magneto Chain. (Three-Speed Models).

Adjustment is done by slackening the platform bolts and sliding the platform backward or forward by means of the draw bolt on the drive side.

### VI.—To Replace Engine Chains.

The old chain is detached at its spring link and the new one connected to the end nearest the Engine by temporarily replacing spring link. The Engine is then rotated to carry the new chain over the Engine Sprocket, after which the old chain is detached and the new one coupled up. If the old chain has already been removed, the new one must be threaded on to the top of the Engine sprocket and the Engine turned in its forward direction. This is greatly facilitated by removing engine top plates and smearing the chain with stiff grease.

After replacement of a High Gear Chain on a two-speed model, or a Magneto Chain, it is necessary to re-set the timing of the magneto. (See Magneto Instructions).

### VII.—Spring Links.

Spring Links should be so fitted that the closed end of the clip points in the direction of travel, to prevent the possibility of it coming off should it meet with any obstruction in its path. With gear chains it should be also on the fly-wheel side. Magneto spring link clips (if ever used) should be on the magneto side.

## THE MAGNETO.

### I.—Its Function.

The Magneto is driven by chain direct from the Engine (on Flying Squirrel Models) or from the gear (on Two-Speed Models), and revolves at the same speed and in the same direction as the Engine. It delivers two sparks per revolution at equal intervals.

The high tension current is only induced when the platinum points of the contact breaker are separated by reason of the fibre-shod arm that carries one of the points, riding upon one of the cams of the contact breaker case. This current is directed to the appropriate sparking plug by means of a distributor. The distributor consists of a vulcanite ring rotating with the armature, having let into it a brass contact piece leading from the high tension winding. This contact piece delivers the high tension current alternately to each of the two carbon-brushes. These are retained by vulcanite holders, set opposite one another, in the magneto casing on the sprocket side.

From the carbon-brush holders the current is led by means of thickly insulated cables to each plug.

### II.—Its Efficiency.

A good spark depends largely upon clean contact breaker points, their correct adjustment, and the free working of the contact breaker and its springs. It further depends upon good contact between the carbon brushes and the distributor ring; also the high tension cables must be sound and properly connected, whilst their insulation must not allow leakage.

The contact breaker points should be adjusted so that they normally open to the width of the gauge of the magneto spanner supplied.

The carbon-brushes and the distributor ring should be cleaned, if necessary, at long intervals.

High tension cables that have become perished should be replaced.

Carbon-brush holders, and sparking plug insulation should be kept clean from dirt, oil or damp.

When sparking plugs have become dirty they should be carefully cleaned (detachable types dismantled). The gap between the electrodes of a plug may become excessive after considerable use due to the metal burning away, and if this is not rectified there is a risk of the spark leaking across the brush holders or some other part in the Magneto, with consequential faulty running and possibly damage to the Magneto. The correct plug gap is .02 in.

## THE MAGNETO.

When in action, the contact breaker points should not spark appreciably. If they do, it usually means that they require cleaning. If this does not remedy matters, it suggests a faulty condenser, which should be rectified by the makers.

### III.—Magneto Timing.

(All Twin Cylinder Models).

To set the timing of the Magneto, remove one of the sparking plugs and retard the ignition lever to its furthest extent.

Turn engine in its normal forward direction until a piston just reaches top dead centre. This can be seen through the plug hole, or felt by inserting a length of stiff wire. Slacken Magneto sprocket fixing nut (or bolt according to type of magneto) and slacken sprocket from the taper spindle by means of light hammer taps from behind, or gentle leverage.

Having removed Contact Breaker Cover turn the Contact Breaker in a forward direction until the platinum points are just fully separated.

Then tighten up sprocket carefully and firmly, taking care that the magneto spindle does not rotate while doing so.

If any doubt exists as to whether the magneto has been timed on the correct cylinder or not, the plug leads should be changed over when attempting to start. Silencer back-fires denote that it is wrong.

Alternatively, if desired, the piston position may be determined from the crank by removing inspection door.

At full retard the crank should be at the top, whilst crank and crankpin centres should lie in a line parallel with cylinders. At full advance this line should approximately point to the rear cylinder holding down bolt or very slightly nearer the vertical.

### IV.—Magneto Cut-Out.

This is operated in combination with the half-compression lever from the handlebar. The purpose of this is to provide that the magneto cut-out is operated only upon half-compression, in order to avoid the sudden jerks in the drive caused by constant switching on and off on full compression. For this reason it is not advisable to fit any extra direct acting switch to the Magneto.

The cut-out switch is situated immediately below the Radiator and comes into action only when half-compression lever is fully operated.

## THE MAGNETO.

### V.—Defective Switch or Switch Wire.

The fault can be traced by detaching first the wire from the contact-breaker cover and then the contact-breaker cover itself if necessary. The fibre bushes by which the switch is insulated from the frame may be defective and can be readily replaced. The contact breaker cover also should be inspected for any possible leakage in the insulation.

For further particulars of Magnetos or Electric Lighting Sets, see Makers' Handbooks.

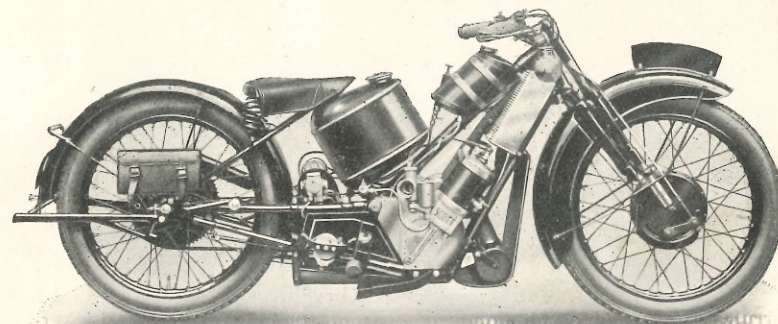

THE SUPER SQUIRREL.

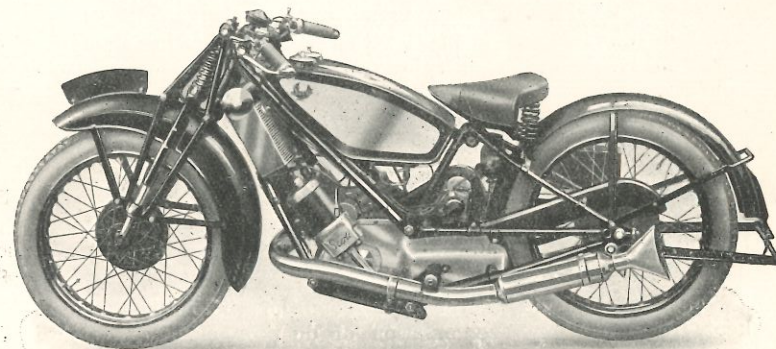

THE NEW POWER-PLUS T.T. REPLICA.

## THE WATER COOLING.

### I.—Its Advantages.

The Cylinders of the Scott Twin Cylinder Engine are completely surrounded with water, in a jacket integral with the casting, surmounted by a detachable aluminium head.

The water conducts the superfluous heat of combustion away from the engine more effectively than can be done by other cooling methods. The cylinders are kept at an ideal and uniform temperature and they are not liable to distortion, which is so difficult to avoid in all but the most skilfully designed air-cooled engines.

The heat of the water is conveyed to the Radiator, which is pierced with innumerable air passages, whence it is finally dispersed to the atmosphere.

It need not be supposed that the Engine is over-heating when the cooling water becomes hot, or if a certain amount of water escapes from the overflow pipe when hot. The Engine is not over-heating unless violent boiling occurs. Even then the engine cannot attain a dangerous temperature so long as sufficient water remains to fill the cylinder jackets. This is yet another safeguard of water-cooling.

### II.—The Radiator.

The three radiator fixing bolts pass through specially strengthened ferrules that relieve the honeycomb from strain. As a further safeguard against the effect of vibration the radiator rests upon rubber washers. These should not be left out, and they should be renewed if damaged or perished.

The level of the water in the radiator should be kept well above the top of the long rubber connecting tube to ensure circulation, which is carried out upon the thermo-syphon principle. If over-filled no harm will result, but any excess will escape from the overflow pipe, which should be kept quite free of obstruction. The level is sufficiently high if water splashes over the baffle inside the filler cap orifice, when the machine is shaken. The water can be drained off by the tap on the side of the cylinder, and this should be done periodically to flush out any deposit. Occasionally the radiator and water jackets should be thoroughly cleaned out by rinsing with soda and water, particularly if a hard water is used habitually. Rain-water is best for the cooling system.

The air passages in the honeycomb of the radiator should be kept free from any accumulation of dust or mud, as otherwise a considerable amount of the cooling area will be lost, and overheating may result. Clean with a stiff brush or scrape off caked mud, if necessary, with a thin piece of soft wood; do not poke out the holes with a hard or sharp instrument as damage may result.

## THE WATER COOLING.

### III.—To Rectify Defects.

Leakage of water from radiator honeycomb can be stopped temporarily with plasticine or by plugging up the defective portion with a bolt and nut having soft washers at each end. It should, of course, be repaired permanently by soldering at the first opportunity.

Leakage from the rubber tube connections can be temporarily cured by the use of insulation tape, but faulty tubes should always be replaced as soon as possible with new ones.

Leakage from the cylinder head can be stopped by tightening down the joints or by replacing the rubber washers.

### IV.—Precautions.

In frosty weather care should be exercised, as with any water-cooled Engine, to guard against freezing of the water, which might cause a fracture. If the machine is kept in an unheated garage where extremes of temperature are likely to be experienced, the water should certainly be drained off when the machine is left for any length of time. When so doing, a tip worth mentioning is to leave the radiator cap removed, as a reminder to prevent the possibility of starting the Engine without re-filling.

There is little fear of the water freezing if the machine is just left for a few hours in an exposed position, unless there is an exceptionally keen frost. Certain preparations are on the market for preventing the freezing of water during ordinary frost and these can safely be used if recommended by reputable suppliers.

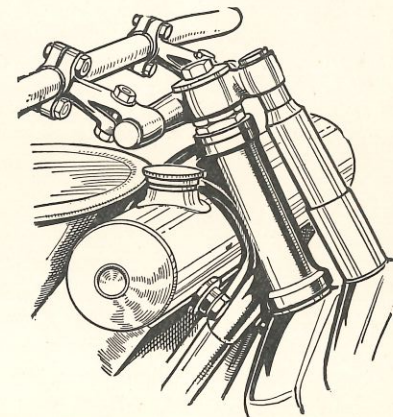

This illustration shows one of the rubber-buffered fixing bolts between the frame and radiator.

## Scott Forks—Super Squirrel Type.

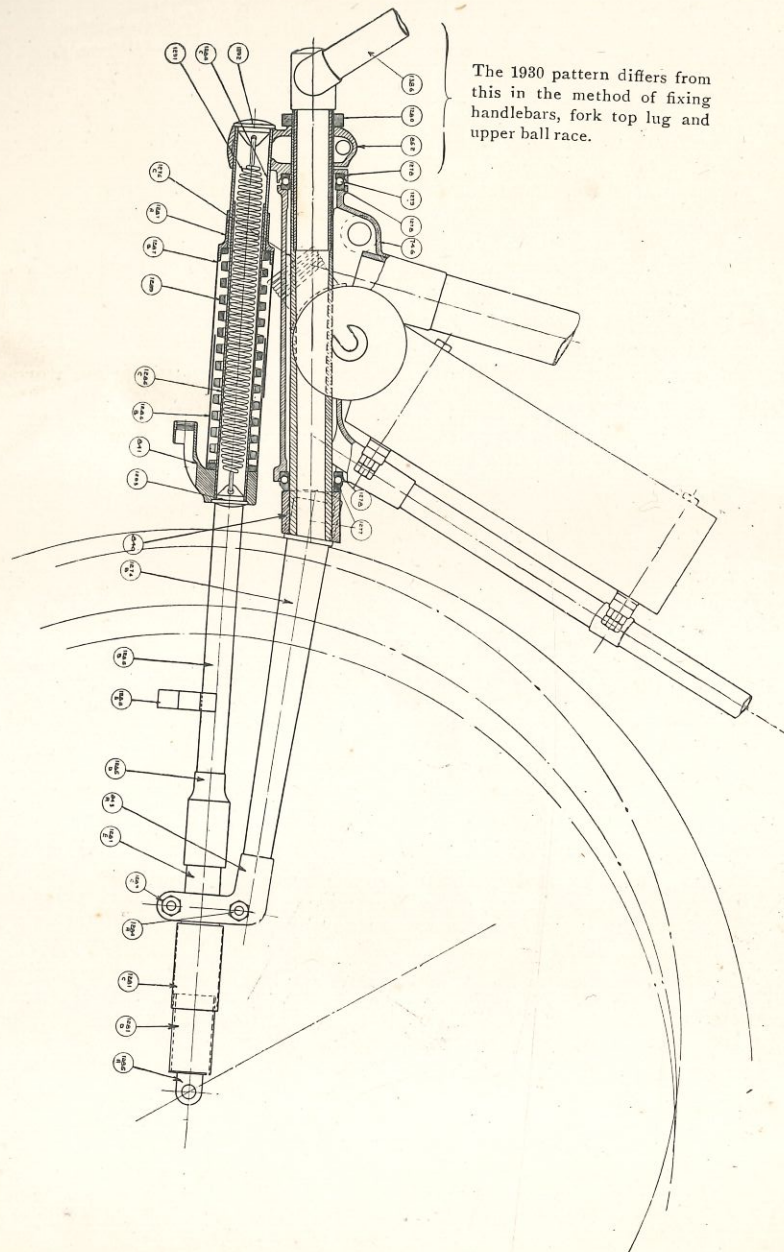

## SCOTT FORKS.

### I.—Super Squirrel Type.

These famous Spring Forks require practically no attention for very long periods, other than lubrication, which should be done at regular intervals without fail. So long as the fork members contain a small supply of oil, lubrication of the bushes is automatic (as described elsewhere, page 19), but if allowed to run dry it may become necessary to flush the forks out with a little paraffin before their normal freedom of movement and flexibility can be restored.

If any side play develops in the guide bushes, it is possible that they may have worked loose in their housing. The clamping bolt of each split lug must be kept tight, as otherwise the bushes will wear externally and require replacement. Normally the guide bushes will last a very long time, but can be renewed quite easily when necessary.

It is important to keep the Head Races in correct adjustment, and to ascertain this, the machine must be put on to its front stand and the head tested for lift or wobble, which should be non-existent; on the other hand there should be no appreciable stiffness. If a steering damper is fitted, remember to slacken this off or preferably to detach it, before testing the head races.

**To Remove the Forks Complete** proceed as follows: With the wheel resting on the ground, insert a screw-driver underneath the top tension spring cap which is above the spring case (immediately in front of the central top hexagon-headed bolt). Then by means of a hooked wire (which can be made from a spoke) pull the tension spring sufficiently to take off the cap. The sliding member is now loose relative to the main fork. Doing this before the wheel is lifted relieves the tension spring and facilitates removal of the cap.

Put the machine on the front stand and remove the wheel, after detaching the brake.

Remove the hexagon-headed bolt from the centre of the fork top lug, which can then be lifted off complete with top spring case and handlebars.

Place a suitable support under the forks, and then remove the large hexagon lock-nut and top head race, both of which have right hand threads.

Upon removing the support, the forks can now be dropped out of the steering head. Be careful not to loose any of the balls.

**To Remove the Sliding Member.** After removing the forks complete, this can be detached by unscrewing the bottom dust caps.

## The Scott Girder Forks.

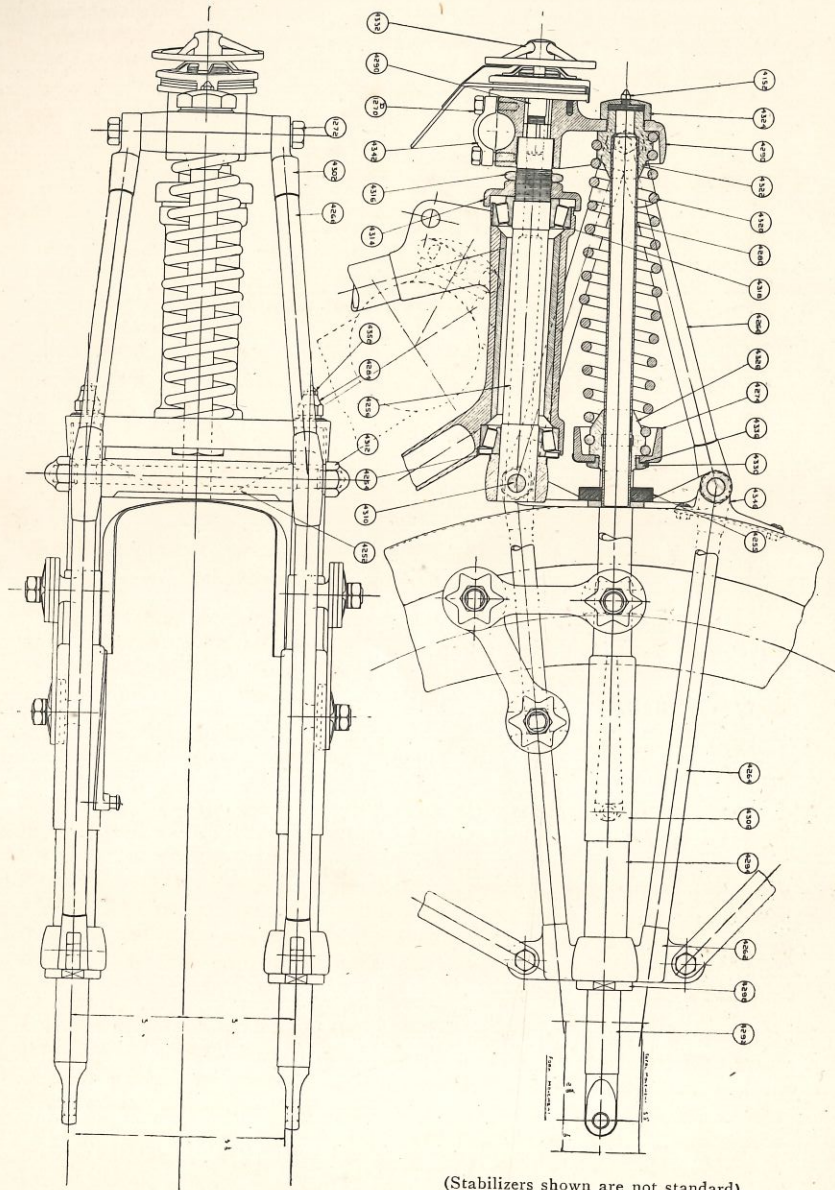

(Stabilizers shown are not standard).

## FORKS.

**To detach Guide Bushes.** These bushes are located in a spherical seating and clamped up by the split lug. To remove them the bolt should be withdrawn and the lug slightly sprung. These bushes may be renewed without removing the forks, if the wheel is taken out and the bottom dust covers first screwed off.

## II.—De Luxe and T.T. Replica Type.

The remarks upon regular lubrication of the Super Squirrel Forks apply equally to the Girder Type Forks of the De Luxe and T.T. Replica Models, and as these forks are built up with detachable components, it is also advisable to examine all nuts and bolts periodically and tighten if necessary. If any lack of rigidity develops the first points to examine are the two "oiler" nuts on the sliding-crown, and the large central nut under the main-crown lug. It is essential that the sliding surfaces should always be well lubricated by means of the three oilers provided. The frequency of such lubrication depends very largely upon the conditions of use, and it is advisable, therefore, to inspect the forks from time to time, in order to ensure that none of the sliding members have worked dry.

**To Remove the Forks Complete.** Proceed as follows: Detach handlebars, leaving cables and controls in position.

After placing the machine on its front stand, detach the front brake rod from the cam lever and remove the front wheel. The removal of the mudguard is not necessary, but may facilitate subsequent operations.

Detach the steering damper and remove the  $\frac{1}{4}$ -inch set screw underneath.

The set screws holding the side girders to the top fork lug should then be taken out. These girders are positioned to the top lug by means of spigots, and to remove the lug they require to be freed from the main fork crown by slackening off two of the hexagon blind nuts on one side, and taking off the large hexagon nut holding the top of the spring. The steering head bearing adjusting nut and lock nut must then be removed, thus allowing the forks to be dropped out of the frame.

If it is required to strip the forks, this is done as follows:— Take off the two blind nuts at the top of the sliding fork crown, and remove the crown together with the spring, by lightly tapping the under side of the crown, or the top of the projecting screws with a piece of wood or similar material, to prevent damage to the threads. The fork guides can then be withdrawn from the bottom fork end lugs, and, by removing the blind nuts in the centre of the girder at one side, each girder can be taken away.

## FORKS.

The spring can be removed from the crown by unscrewing the nut on the under side of the crown, or simply screwing the spring off its anchor.

In assembling the forks, the reverse procedure should be carried out, taking care to bolt up the front wheel before finally locking the two blind nuts on the top side of the sliding fork crown. This is in order to make sure that the fork guides are not on the twist.

### III.—Flying Squirrel Type (Webb).

These lighter forks provide a large range of free spring movement which, however, may be damped down by means of the friction discs, with quick finger adjustment. The forks must be kept well lubricated by means of the four grease-gun nipples. Grease working out at the ends of the bushes is the surest indication of adequate lubrication.

Side play should not be allowed to develop in the fork bushes, the adjustment of these being correct when the knurled washers at each end are just free to rotate without allowing actual side movement.

To adjust these bushes, first slacken off the lock-nuts at the left-hand side of forks, then the lock-nuts at the right-hand side. The bush spindles can then be screwed in or out by means of the square heads at their right hand end. Re-tighten first the right-hand lock nuts and then the left-hand, and finally test the knurled washers for correct adjustment as described above.

**To Remove Webb Forks Complete.** Detach handlebars, leaving controls and cables in position.

Place machine on its front stand and remove wheel and mudguard if desired.

Remove domed lock nut, slacken lug clamping bolt, and tap up the top lug, which will then lift off, without detaching the spring.

The steering head bearing adjusting cap and lock-nut can then be removed, allowing the forks to be dropped out.

In re-assembling the forks, the reverse procedure should be carried out, and the steering head bearing adjusted.

### IV.—Steering Head Bearings.

#### (Flying Squirrel, De Luxe and T.T. Replica).

These bearings are of the taper roller type, and great care should be exercised in adjusting them. After slackening off the Steering Damper, if fitted, the front wheel should be lifted free of the ground; then proceed as follows :

## FORKS.

Tighten up the bearing by means of the head adjusting nut, and then slacken off until the Handlebars are just free, finally locking up with the lock nut.

Should wear take place, adjust the bearings upon its first appearance. Do not allow head shake to develop.

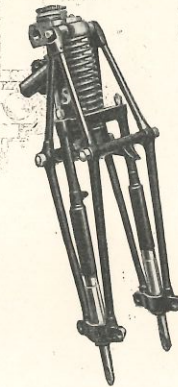

The Scott Girder Forks as fitted to Flying Squirrel De Luxe and T.T. Replica.

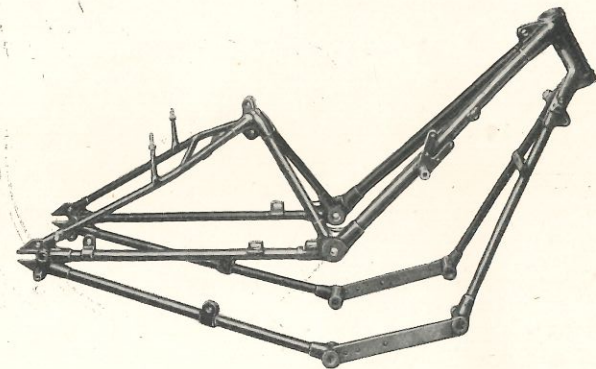

The Scott Frame—Flying Squirrel Type. The top-tube (not shown) carries the petrol tank and is readily detachable.

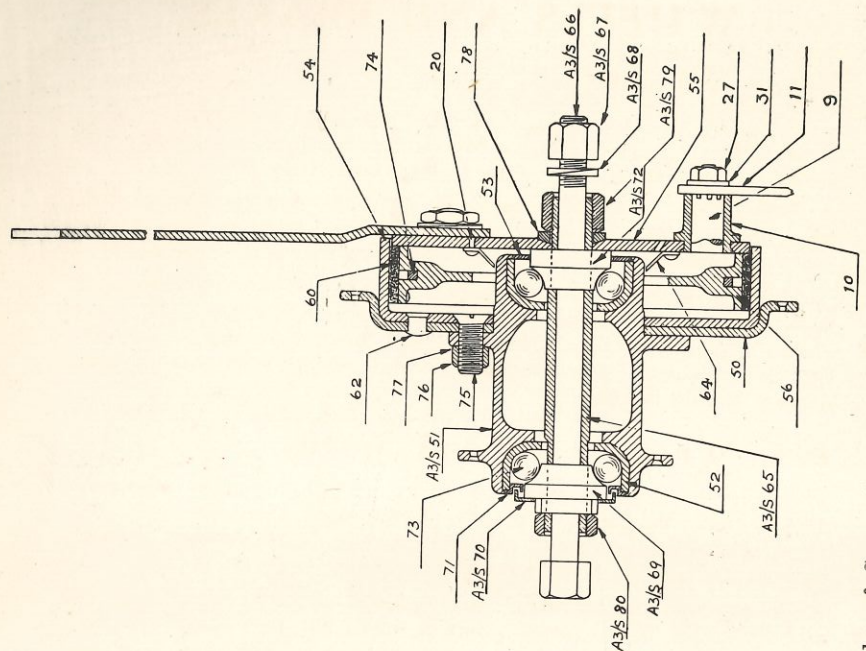

Front Wheel Hub and Brake of Super Squirrel Models.

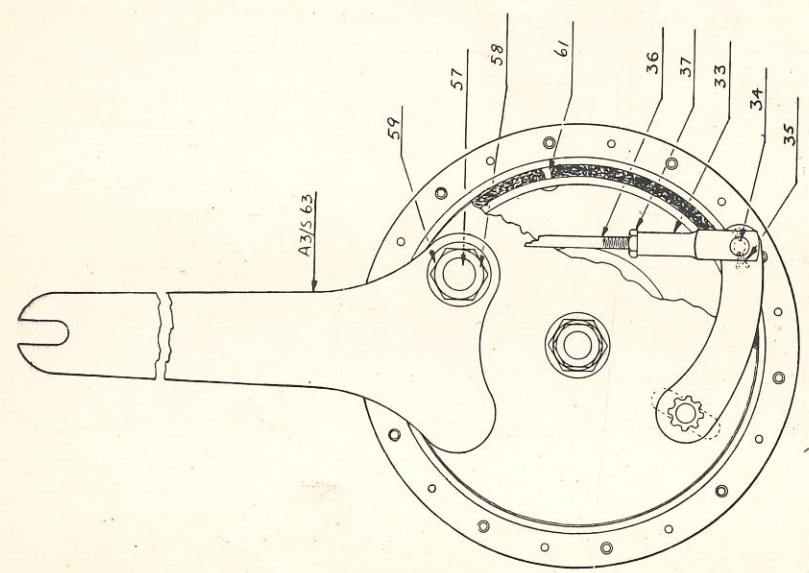

## WHEELS AND BRAKES.

### Front Wheels.

These are all of the cup and cone type, and with the exception of the Flying Squirrel Tourer Model, the bearings are mounted on a separate hollow spindle to facilitate wheel removal.

Adjustment is by the ordinary method. Release spindle bolt, which holds wheel in position, then take up play by moving the near side cone as required, afterwards re-tightening the spindle.

The bearing cups are lightly pressed into the hub and, therefore, require only a soft punch and light hammer for removal. The punch should be placed through the hub shell, to rest on the back of the cup, and the point of contact moved from side to side, thus avoiding damage to the housing.

### Rear Wheel—Super and Sports.

non-adjustable

The rear wheel bearings of these models consist of ~~adjustable~~ double row ball journals, pressed lightly into the hub shell. The pieces protruding at each side of the wheel are actually distance bushes, and not part of the hollow spindle.

To examine the bearings, after removal of wheel from frame and dismantling of brake parts, insert a small bar to a depth of about half-an-inch in each of the protruding bushes; apply leverage and this will cause the brass caps (which are dust washers) to spring out of position, thus exposing the bearings themselves and the hollow spindle.

To remove the bearings use a soft punch on one end of the hollow spindle, and this will cause the opposite bearing to leave the hub. The remaining one can then be forced out of position, applying the punch through the hub shell.

When replacing, care should be taken to have the hub clean and to press each bearing home with a piece of tube or something which will register with the outer race. Before the brass cap and centre bush is replaced, the felt washer positioned behind the cap on the bush should be well greased. The cap is also a press fit into the hub, and can be tapped into position; it must be tight enough to exclude moisture, to ensure which the hub can be caulked over a little if necessary.

### Rear Wheel—Flying Squirrel Tourer.

These bearings are of the taper roller type with plain centre races, and adjustment is easily made by releasing the wheel spindle nut on the near side, slacking back the lock nut, which is nearest the fork end lug, and then screwing up the inside nut, which faces on the centre of bearing, the required amount. Care should be taken to re-lock the nuts.

## Rear Hub and Brake. Super and Sports Type.

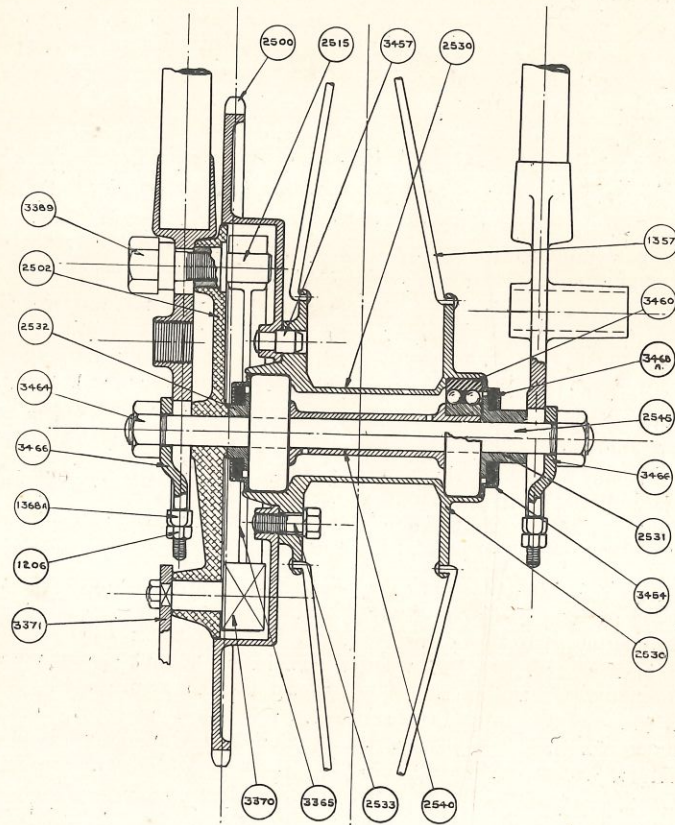

## WHEELS AND BRAKES.

### Rear Wheel—De Luxe and Replica.

These bearings are also of taper roller pattern, but the centre is screwed to act as a cone.

To adjust, release the wheel fixing nut, slack back the large shoulder nut, then screw up the portion of bearing protruding from dust cap (there are two machined faces for the spanner), after which the lock nut should be re-tightened.

The outer shells of all taper roller bearings are a light press fit into the hub, and the method of removal is precisely the same as that for front wheel cups.

Particular care should be taken with all taper bearings; if too tight the outer cage and rollers will be damaged.

Correct adjustment of any wheel bearing is such that allows the wheel to be spun freely and yet does not allow more than the merest trace of play when the rim is pressed sideways. Adjustment should invariably be checked **after** tightening up lock nuts and spindle nuts.

### Brakes.

Both the front and rear brakes on all models are of the internal expanding type, and the method of adjusting them to take up wear of the linings should become obvious at a glance. Adjustment is best carried out with the machine on its stands and the wheels perfectly free to revolve.

Spring loaded finger adjusting nuts are provided on all brakes except the rear of two-speed models, which has a hexagon sleeve nut. The nut should be screwed up until the brake shoes just begin to touch the brake drum (which can be felt by revolving the wheel), and then it should be slackened back until the wheel is just free; the best position will, however, soon be found by experiment.

The above instructions apply to the spring loaded type of adjusters, and with these, it will sooner or later become necessary to screw the spring tensioning nut further along the rod.

In the case of the two-speed rear brake adjustment is made by slackening off the lock nut and screwing up the sleeve nut, after which, the lock nut must be tightened again.

If the brakes are not adjusted sufficiently tight, too much pedal or hand lever movement will be necessary before they come into operation, and on the other hand, if adjusted too tight, power will

## WHEELS AND BRAKES.

be absorbed in the constant rubbing of the brake shoes. Whenever the rear wheel is moved in the frame, it will be necessary to re-adjust the rear brake.

The brake drums and mechanism should be cleaned out periodically, and kept free from any excess of oil, such as might result from over-lubricated wheel bearings. Brake linings should be replaced immediately they become thin or show signs of getting ragged.

It must be remembered that the brakes of your machine are most important components, and should be kept in efficient working order, ready for any emergency. Good brakes, in addition to being essential for safety in modern traffic conditions, promote a feeling of pleasure and security by the knowledge that your machine is, at all times, under perfect control.

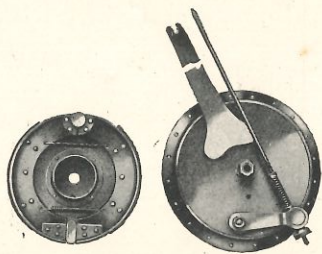

The Flying Squirrel Front Brake.

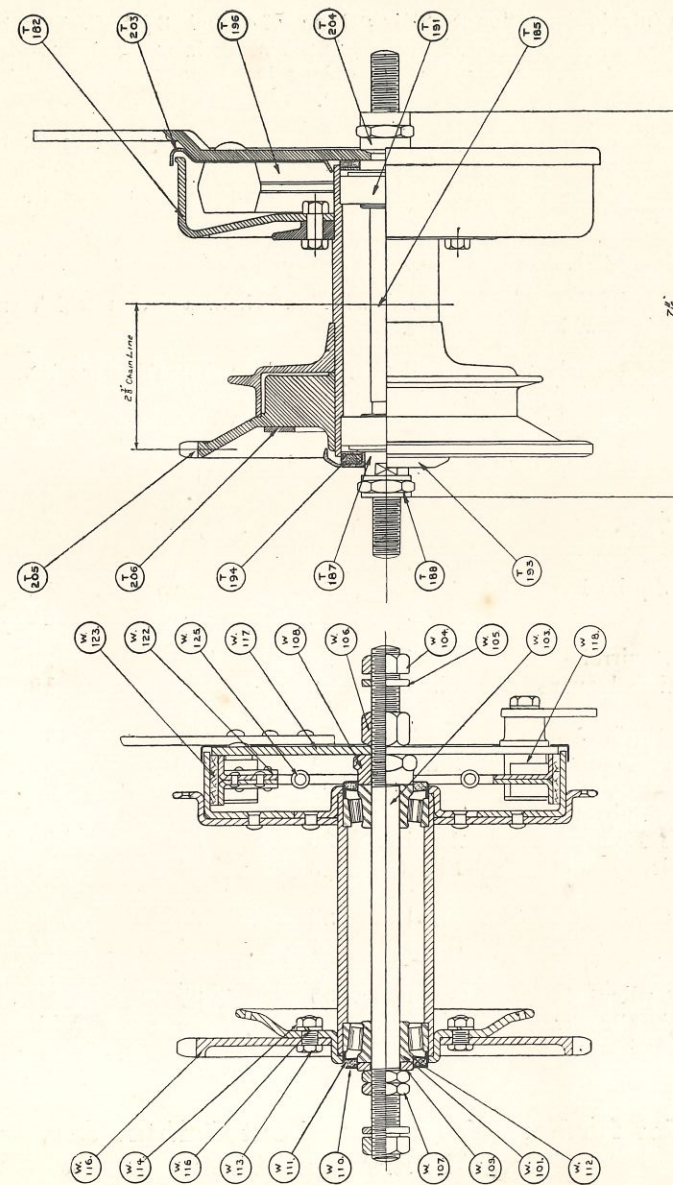

De Luxe and Replica Type.

Rear Hub and Brake of Flying Squirrel Tourer  
(Webb Type).

## CARBURETTER.

The straight-on flange fitting type of Amal 3-jet Carburetter, fitted to all Flying Squirrel Models, is made specially for the "Scott," and is suitable both for touring and racing purposes, the jet sizes of course being arranged accordingly.

We give below jet sizes which have been found most suitable, but owing to varying conditions, the rider should find by experiment the best sizes to suit his requirements. The same sizes usually apply for both 498 cc. and 596 cc. Engines.

On Super Squirrel Models an Amal 2-jet Carburetter is fitted.

All Models may be equipped with an Air-Cleaner, in which case smaller jets will be necessary.

Earlier Models were fitted with Binks' or Amac Carburetters of a type very similar to the Amal now used.

### Recommended Jet Sizes.

Type of Machine and Carburetter		Pilot Jet (Nearest Engine).	Centre Jet (Compensating)	Main Jet (Nearest Intake).
Super Squirrel	Amal	30	—	110
	Binks	2	—	12
Super Squirrel with Air Cleaner	Amal	25	—	90
	Binks	2	—	12
Flying Squirrel and De Luxe	Amal	35	50	110
	Binks	4	5	13
Flying Squirrel and De Luxe with Air Cleaner	Amal	30	35	90
	Binks	3	4	9
T.T. Replica	Amal	35	35	120
	Binks	4	4	14
T.T. Replica with Air Cleaner	Amal	30	35	90
	Binks	3	4	9

For further information about Carburetters, See Makers' Handbook.

## TABLES OF GEAR RATIOS, 1930.

### TWO-SPEED.

### THREE-SPEED.

Number of Teeth in Sprockets					Ratios		No. of Teeth in Sprockets.				Ratios		
E	H	L	R	D	HG	LG	E	G	R	D	HG	MG	LG
Wide Ratio													
20	25	47	66	22	3'75	7'06	20	44	40	22	4'00	7'03	11'52
"	"	"	"	21	3'93	7'40	"	"	"	21	4'18	7'35	12'20
"	"	"	"	20	4'13	7'75	"	"	"	20	4'40	7'72	12'70
"	"	"	"	19	4'34	8'16	"	"	"	19	4'62	8'12	13'30
20	25	47	75	22	4'26	8'00	"	"	"	18	4'90	8'60	14'10
"	"	"	"	21	4'46	8'40	"	"	"	17	5'17	9'08	14'90
"	"	"	"	20	4'69	8'81	"	"	"	16	5'50	9'65	15'85
"	"	"	"	19	4'93	9'27	"	"	"	16	5'50	9'65	15'85
Close Ratio													
20	25	40	66	22	3'75	6'00	20	44	40	22	4'00	5'28	7'04
"	"	"	"	21	3'93	6'30	"	"	"	21	4'18	5'50	7'38
"	"	"	"	20	4'13	6'60	"	"	"	20	4'40	5'80	7'75
"	"	"	"	19	4'34	6'95	"	"	"	19	4'62	6'10	8'15
20	25	40	75	22	4'26	6'82	"	"	"	18	4'90	6'46	8'61
"	"	"	"	21	4'46	7'14	"	"	"	17	5'17	6'82	9'12
"	"	"	"	20	4'69	7'50	"	"	"	16	5'50	7'25	9'70
"	"	"	"	19	4'93	7'89	"	"	"	16	5'50	7'25	9'70

E = Engine Sprockets.  
H = High Gear Sprocket.  
L = Low Gear Sprocket.  
R = Rear Wheel Sprocket.  
D = Driving Sprocket.  
HG = High Gear.  
LG = Low Gear.

E = Engine Sprocket.  
G = Gear Box Sprocket.  
R = Rear Wheel Sprocket.  
D = Driving Sprocket.  
HG = High Gear.  
MG = Middle Gear.  
LG = Low Gear.

### STANDARD GEAR RATIOS FOR 1930 Models.

#### Solo

#### Sidecar

Model	Low Gear	Middle Gear	High Gear	Driv. Spkt.	Low Gear	Middle Gear	High Gear	Driv. Spkt.
498 cc. Super Squirrel	7'75	—	4'13	20	9'27	—	4'93	19/75
596 cc. " "	7'06	—	3'75	22	9'27	—	4'93	19/75
498 cc. Touring Flyer	13'30	8'12	4'62	19	14'90	9'08	5'17	17
596 cc. " "	12'20	7'35	4'18	21	13'30	8'12	4'62	19
498 cc. De Luxe Flyer	13'30	8'12	4'62	19	14'90	9'08	5'17	17
596 cc. " "	12'20	7'35	4'18	21	13'30	8'12	4'62	19
498 cc. Replica Flyer	8'15	6'10	4'62	19	9'12	6'82	5'17	17
596 cc. " "	7'75	5'80	4'40	20	8'61	6'46	4'90	18

NOTE.—The Two-Speed Standard Ratios are intended for average conditions. For Solo work in very hilly districts, sidecar ratios can be used with advantage, whilst for heavy sidecar work with Two-Speed Models, the lowest possible ratios should be selected.

DROP US A LINE.

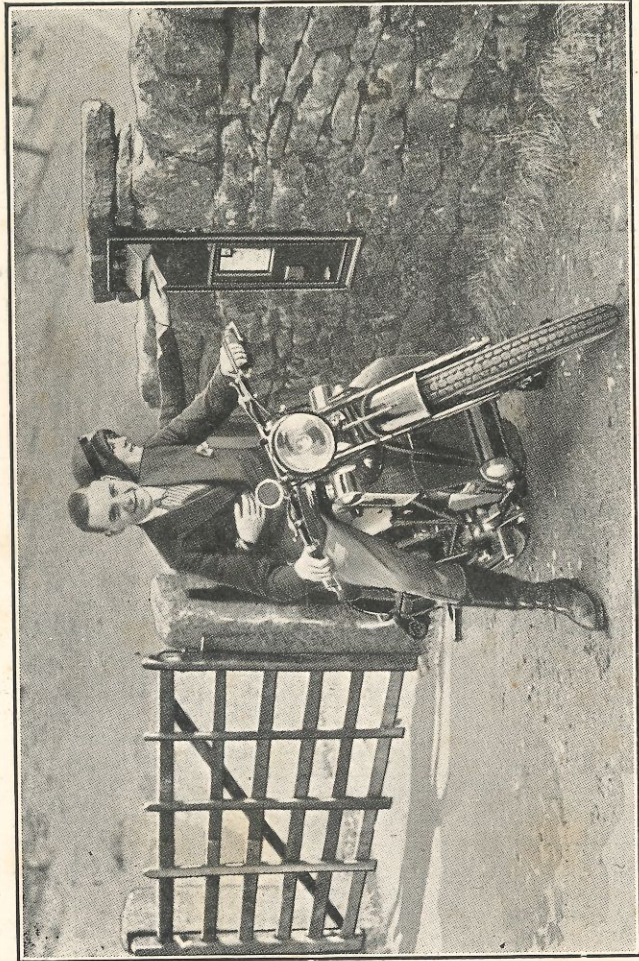

Whenever you feel like writing to us—please do so! We are at all times happy to afford information, advice, and assistance to ensure the utmost satisfaction being obtained from every Scott. (Please be sure to quote Engine Number).

Always at your Service—THE SCOTT MOTOR CYCLE CO. LTD.

**Scott**

